



BSI Standards Publication

# Low-voltage surge protective devices

Part 11: Surge protective devices connected to low-voltage power systems — Requirements and test methods

NO COPYING WITHOUT BSI PERMISSION EXCEPT AS PERMITTED BY COPYRIGHT LAW

### National foreword

This British Standard is the UK implementation of EN 61643-11:2012. It is derived from IEC 61643-11:2012. It supersedes BS EN 61643-11:2002 which is withdrawn.

The UK participation in its preparation was entrusted by Technical Committee PEL/37, Surge Arresters — High Voltage, to Subcommittee PEL/37/1, Surge Arresters — Low Voltage.

A list of organizations represented on this committee can be obtained on request to its secretary.

This publication does not purport to include all the necessary provisions of a contract. Users are responsible for its correct application.

© The British Standards Institution 2012

Published by BSI Standards Limited 2012

ISBN 978 0 580 54739 3

ICS 29.240.01; 29.240.10

### Compliance with a British Standard cannot confer immunity from legal obligations.

This British Standard was published under the authority of the Standards Policy and Strategy Committee on 30 November 2012.

### Amendments issued since publication

Amd. No.	Date	Text affected
----------	------	---------------

---

EUROPEAN STANDARD  
 NORME EUROPÉENNE  
 EUROPÄISCHE NORM

**EN 61643-11**

October 2012

ICS 29.240; 29.240.10

Supersedes EN 61643-11:2002 + A11:2007

English version

**Low-voltage surge protective devices -  
 Part 11: Surge protective devices connected to low-voltage power  
 systems -  
 Requirements and test methods  
 (IEC 61643-11:2011, modified)**

Parafoudres basse tension -  
 Partie 11: Parafoudres connectés aux  
 systèmes basse tension -  
 Exigences et méthodes d'essai  
 (CEI 61643-11:2011, modifiée)

Überspannungsschutzgeräte für  
 Niederspannung -  
 Teil 11: Überspannungsschutzgeräte für  
 den Einsatz in Niederspannungsanlagen -  
 Anforderungen und Prüfungen  
 (IEC 61643-11:2011, modifiziert)

This European Standard was approved by CENELEC on 2012-08-27. CENELEC members are bound to comply with the CEN/CENELEC Internal Regulations which stipulate the conditions for giving this European Standard the status of a national standard without any alteration.

Up-to-date lists and bibliographical references concerning such national standards may be obtained on application to the CEN-CENELEC Management Centre or to any CENELEC member.

This European Standard exists in three official versions (English, French, German). A version in any other language made by translation under the responsibility of a CENELEC member into its own language and notified to the CEN-CENELEC Management Centre has the same status as the official versions.

CENELEC members are the national electrotechnical committees of Austria, Belgium, Bulgaria, Croatia, Cyprus, the Czech Republic, Denmark, Estonia, Finland, Former Yugoslav Republic of Macedonia, France, Germany, Greece, Hungary, Iceland, Ireland, Italy, Latvia, Lithuania, Luxembourg, Malta, the Netherlands, Norway, Poland, Portugal, Romania, Slovakia, Slovenia, Spain, Sweden, Switzerland, Turkey and the United Kingdom.

**CENELEC**

European Committee for Electrotechnical Standardization  
 Comité Européen de Normalisation Electrotechnique  
 Europäisches Komitee für Elektrotechnische Normung

**Management Centre: Avenue Marnix 17, B - 1000 Brussels**

## Foreword

This document (EN 61643-11:2012) consists of the text of IEC 61643-11:2011 prepared by IEC/SC 37A "Low-voltage surge protective devices", together with the common modifications prepared by CLC/TC 37A "Low voltage surge protective devices".

The following dates are fixed:

- latest date by which this document has to be implemented (dop) 2013-08-27  
at national level by publication of an identical national standard or by endorsement
- latest date by which the national standards conflicting with this document have to be withdrawn (dow) 2015-08-27

This document supersedes EN 61643-11:2002 + A11:2007.

The main changes with respect of EN 61643-11:2002 + A11:2007 are the complete restructuring and improvement of the test procedures and test sequences.

Clauses, subclauses, notes, tables, figures and annexes which are additional to those in IEC 61643-11:2011 are prefixed "Z".

Attention is drawn to the possibility that some of the elements of this document may be the subject of patent rights. CENELEC [and/or CEN] shall not be held responsible for identifying any or all such patent rights.

This standard covers the Principle Elements of the Safety Objectives for Electrical Equipment Designed for Use within Certain Voltage Limits (LVD - 2006/95/EC)

---

## Endorsement notice

The text of the International Standard IEC 61643-11:2011 was approved by CENELEC as a European Standard with agreed common modifications.

### COMMON MODIFICATIONS

**Scope** *Modify the Scope as follows:*

This part of EN 61643 is applicable to devices for surge protection against indirect and direct effects of lightning or other transient overvoltages. These devices are called Surge Protective Devices (SPD). These devices are designed to be connected to 50 Hz a.c. power circuits, and equipment rated up to 1 000 V r.m.s. Performance characteristics, safety requirements, standard methods for testing and ratings are established. These devices contain at least one nonlinear component and are intended to limit surge voltages and divert surge currents.

**3.1.14** *Modify the note as follows:*

- the measured limiting voltage, determined for front-of-wave sparkover (if applicable) and the measured limiting voltage, determined from the residual voltage measurements up to  $I_n$  and/or  $I_{imp}$  respectively for test classes II and/or I
- the measured limiting voltage determined for the combination wave measurements up to  $U_{oc}$  for test class III.

**3.1.28** *Modify the definition as follows:*

**SPD disconnecter (disconnecter)**

device for disconnecting an SPD, or part of an SPD, from the power system in the event of SPD failure

NOTE This disconnecting device is not required to have isolating capability for safety purposes. It is to prevent a persistent fault on the system and is used to give an indication of an SPD's failure. Disconnectors can be either internal (built in) or external (required by the manufacturer) or both. There may be more than one disconnector function, for example an over-current protection function and a thermal protection function. These functions may be in separate units.

**3.1.36** *Modify the heading definition as follows:*

**sparkover voltage or trigger voltage of a voltage switching SPD**

**3.1.39** *Add a note to the definition:*

NOTE According to installation standard HD 60364-5-534,  $I_{fi}$  shall be equal to  $I_{scc}$ .

**4.1** *Modify the subclause as follows:*

Frequency range is from 47 Hz to 53 Hz a.c.

**5.3** *Replace 5.3 by the following:*

**Types 1, 2 and 3 SPDs- Class I, II and III tests**

Information required for class I, II and class III tests is given in Table 2.

**Table 2 – Tests of types 1, 2 and 3 SPDs**

Type of SPD	Tests	Required information	Test procedures (see subclauses)
Type 1	Class I	$I_{imp}$	8.1.1; 8.1.2; 8.1.3
Type 2	Class II	$I_n$	8.1.2; 8.1.3
Type 3	Class III	$U_{oc}$	8.1.4; 8.1.4.1

**5.7.1.3** *Modify the title as follows:*

**Both (one part internal and one part external)**

**5.8** *Delete text:*

According to IP code of IEC 60529.

**5.10.1** *Modify the subclause as follows:*

AC between 47 Hz and 53 Hz.

**5.10.2** *Modify the subclause as follows:*

AC other than the range of 47 Hz to 53 Hz.

**6** *Replace complete clause by:* void

**Table 1** *Delete row k dealing with k (trip current factor)*

**7.1.1** *Modify a4) as follows:*

The SPD type and discharge parameters for each mode of protection declared by the manufacturer and printed next to each other:

- for Type 1: “Type 1” and “ $I_{imp}$ ” and the value in kA, and/or “ $\overline{T1}$ ” (T1 in a square) and “ $I_{imp}$ ” and the value in kA (e.g.  $\overline{T1}$   $I_{imp}$ : 10 kA);
- for Type 2: “Type 2” and “ $I_n$ ” and the value in kA, and/or “ $\overline{T2}$ ” (T2 in a square) and “ $I_n$ ” and the value in kA (e.g.  $\overline{T2}$   $I_n$ : 10 kA);
- for Type 3: “Type 3” and “ $U_{oc}$ ” and the value in kV, and/or “ $\overline{T3}$ ” (T3 in a square) and “ $U_{oc}$ ” and the value in kV (e.g.  $\overline{T3}$   $U_{oc}$ : 5 kV);

**7.1.1** *Modify last paragraph of a8) as follows:*

An SPD may be classified according to more than one test class (e.g. Type 1  $\overline{T1}$  and Type2  $\overline{T2}$ ). In this case, the tests required for all declared test classes shall be performed. If in such case the manufacturer declares only one protection level, only the highest protection level shall appear in the marking.

**7.1.1** *Modify b10) to read*

b10) void

**7.1.1** *Modify b14) to read*

b14)  $I_{\max}$ , (if declared by the manufacturer).

**7.1.1** *Modify c7) to read*

c7) void

**7.2.2** *Add a 3<sup>rd</sup> paragraph:*

This test is not performed on SPDs for connection N-PE only.

**7.2.4** *Add after the first paragraph:*

*The SPD shall be .....changes in its characteristics.*

“In addition voltage switching type SPDs or combination type SPDs shall be able to interrupt any follow current up to the short-circuit current rating ( $I_{\text{scrc}}$ ).”

**7.2.5.3** *Modify the 2<sup>nd</sup> paragraph to read:*

Compliance is checked by the test in accordance with 8.3.5.3 and 8.3.5.3.2.

**7.2.5.3** *Remove the 3<sup>rd</sup> paragraph*

**7.2.5.4** *Replace the 2<sup>nd</sup> paragraph by:*

A status indicator may be composed of two parts (one of which is not replaced when e.g. a plug module is changed), linked by a coupling mechanism which can be mechanical, optical, audio, electromagnetic, etc. The part of the status indicator which is not replaced (e.g. base part of socket) shall be capable of operating at least 50 times

**7.4.5.1** *Replace reference to IEC 61000 series by reference to EN 61000-6-1.*

**7.4.5.2** *Replace reference to IEC 61000 series by reference to EN 61000-6-3.*

**7.6.1.2** *Add new requirement:*

**7.6.1.2 Maximum discharge current  $I_{\max}$**

If the manufacturer declares  $I_{\max}$  this parameter shall be tested in accordance with the test in 8.3.3.1.

**7.6.1.3** *Add new requirement:*

**7.6.1.3 Vibration and shock**

Information on vibration and shock tests for transportation and special applications can be found in Annex ZB.

**8** *Modify the note as follows:*

NOTE For some tests, special prepared samples are required.

**8.1** *Add the following Note after the 11<sup>th</sup> paragraph (second bullet):*

NOTE Tissue paper: thin, soft and rather strong paper, generally used to wrap breakable objects and whose weight stands between 12 g/m<sup>2</sup> and 25 g/m<sup>2</sup>.

**8.1** *Correct miss spelling at the end of 2<sup>nd</sup> line of the 10<sup>th</sup> paragraph:*

... is required for the L-PE ... *(the t of the word the is missing)*

**Table 3** *Add footnote<sup>d</sup> to the line "Operating duty test" in Table 3.*

**Table 3** *Add footnote<sup>d</sup> to read as follows (bottom of Table 3):*

<sup>d</sup> For the whole operating duty test (including the additional duty test, if applicable) one separate set of samples may be used.

**Table 3** *Replace the test description in test sequence 7 "For SPDs classified outdoor" to read:*

Environmental tests for outdoor SPDs

**Table 3** *Replace in the line of test sequence 7 "O" by "-"*

Delete "O = optional" in Table 3 (bottom)

**Table 3** *Add after Thermal stability "c"*

**Table 4, E criteria** *Modify second paragraph as follows:*

The SPD shall be connected as for normal use according to the manufacturer's instructions to a power supply at the reference test voltage ( $U_{REF}$ ). The current that flows through each terminal is measured. Its resistive component (momentary value of current measured at the crest of the voltage sine wave) shall not exceed a value of 1 mA, or the total current shall not have changed by more than 20 % compared to the initial value determined at the beginning of the relevant test sequence.

**Table 4, E criteria** *Modify fourth paragraph as follows:*

In addition, for SPD modes connected N-PE only the current through the PE-terminal shall be measured, whereas the terminals are connected to a power supply at the maximum continuous operating voltage ( $U_c$ ). Its resistive component (momentary value of current measured at the crest of the voltage sine wave) shall not exceed a value of 1 mA, or the total current shall not have changed by more than 20 % compared to the initial value determined at the beginning of the relevant test sequence.

**Table 5** *Delete line 8.3.5.3.1*

**8.3.2** *Replace the 1<sup>st</sup> paragraph to read:*

All modes of protection of the SPD shall be connected as for normal use according to the manufacturer's instructions.

The line to PE voltage of the supply system shall be adjusted to the reference test voltage  $U_{REF}$ .

8.3.3

Replace Figure 5 by:

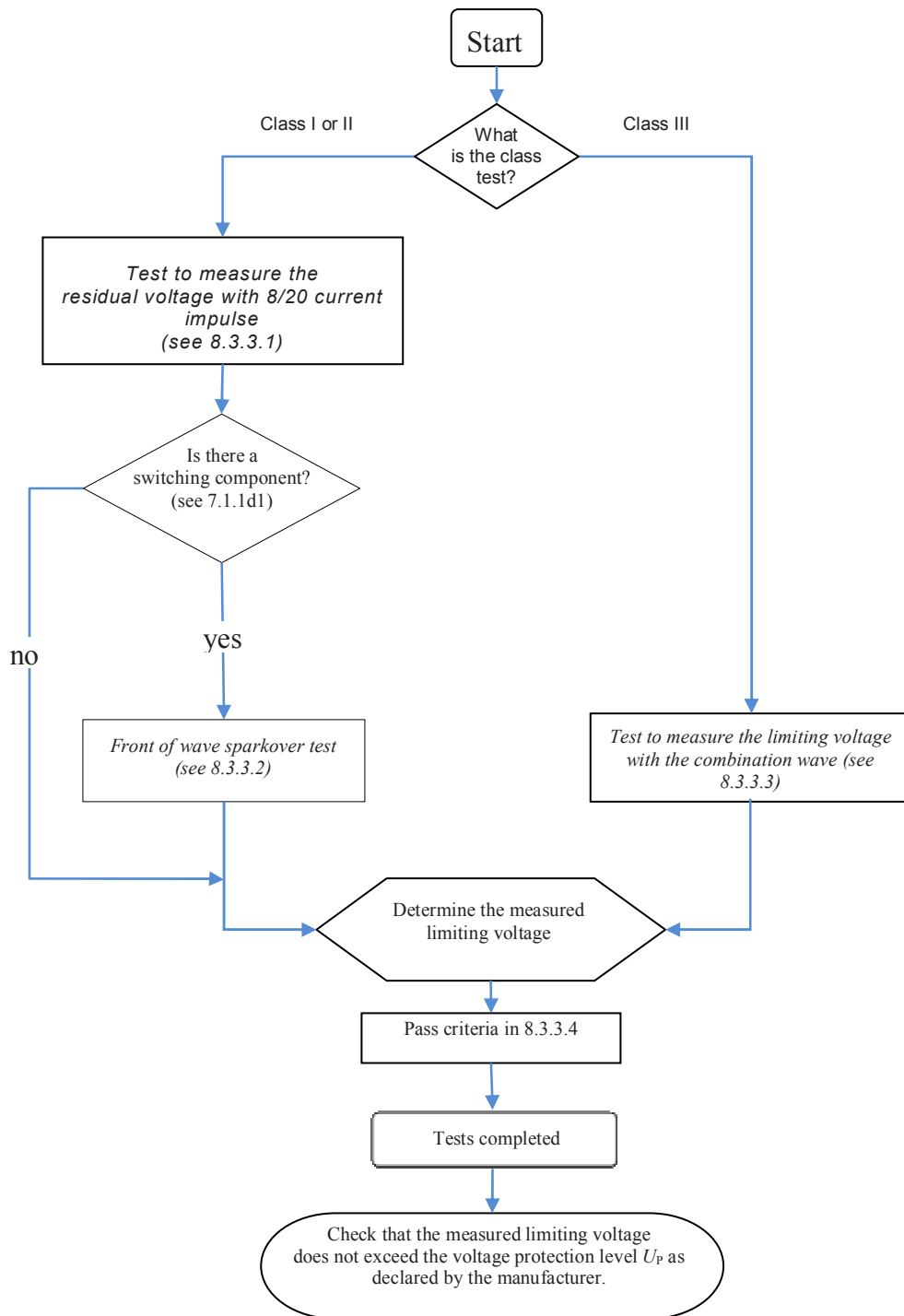

**8.3.3.1** *Replace the whole clause by*

**Residual voltage with 8/20 current impulses**

- a) When testing SPDs to class I, 8/20 current impulses with a sequence of crest values of approximately 0,1; 0,2; 0,5; 1,0 times the crest value of  $I_{imp}$  shall be applied.

When testing SPDs to class II, 8/20 current impulses with a sequence of crest values of approximately 0,1; 0,2; 0,5; 1,0 times  $I_n$  shall be applied.

If the SPD contains only voltage-limiting components, this test needs only to be performed at crest values of  $I_{imp}$  for test class I or  $I_n$  for test class II.

One sequence of positive polarity and one sequence of negative polarity are applied to the SPD.

- b) When  $I_{max}$  is declared by the manufacturer an additional 8/20 current impulse with a crest value of  $I_{max}$  shall be applied at the polarity that showed higher residual voltages in the previous tests a).
- c) The interval between individual impulses shall be long enough for the sample to cool down to ambient temperature.
- d) A current and a voltage oscillogram shall be recorded for each impulse. If relevant, the (absolute) crest values shall be plotted into a discharge current versus residual voltage diagram to  $I_n$  or  $I_{imp}$ . A curve which best fits the data points shall be drawn. There shall be sufficient points on the curve to ensure that there are no significant deviations on the curve up to  $I_n$  or  $I_{imp}$ .
- e) The residual voltage used for determining the measured limiting voltage is the highest voltage value corresponding to the range of currents for
- class I: up to  $I_{imp}$ ;
  - class II: up to  $I_n$ .

NOTE The residual voltage is the highest crest value measured during surge current flow. Any high frequency disturbances and spikes before and during current flow caused by specific generator design, like crowbar generators, are disregarded.

- f) The value for determining  $U_{max}$  is the highest residual voltage measured at surge currents up to  $I_n$ ,  $I_{max}$  or  $I_{imp}$ , as applicable depending on the SPD test class.

**8.3.4.1** *Replace the 3<sup>rd</sup> and 4<sup>th</sup> paragraphs starting with "The measured limiting...." and ending with "...negative surge applied." to read:*

The measured limiting voltage shall be checked and shall be below or equal to  $U_P$ .

The measured limiting voltage shall be determined, using the tests described in 8.3.3, but the test of 8.3.3.1 is performed only with an 8/20-surge current with a crest value corresponding to  $I_{imp}$  for Test Class I or with  $I_n$  for Test Class II and the test of 8.3.3.3 is performed only at  $U_{oc}$  for Test class III.

**8.3.4.2.2** *Replace the whole paragraph by:*

The test sample shall be connected to a power frequency voltage at  $U_c$  with a prospective short-circuit current equal to the short circuit current rating  $I_{scsr}$  declared by the manufacturer and with a power factor in accordance with Table 8, except for SPDs which are only connected between neutral and protective earth in TT- and/or TN-Systems, for which the prospective short-circuit current shall be at least 100 A.

**8.3.5.2** *Add a note to the thermal stability test at the end of sample preparation:*

NOTE Separate prepared sets of samples may be needed for this test.

**8.3.5.3** *Modify the text of 2nd paragraph of Test procedure in a) to read:*

**Test**

**Procedure**

The test is carried out twice with  $U_{REF}$  applied once at  $(45 \pm 5)$  electrical degrees and once at  $(90 \pm 5)$  electrical degrees after the zero crossing of the voltage

**8.3.5.3.1 and Table 5** *Remove the entire part. And the relevant line in Table 5.*

**8.3.5.3.2** *Add the sentence after the 2 bullets:*

For all types of SPDs with  $U_c$  up to 180 V, the conditioning voltage may be reduced to 600 V" if for voltage switching type SPDs and for combination type SPDs, any voltage switching components operate at this voltage.

**8.3.5.3.2** *Replace the full last paragraph of Test procedure by:*

**Test**

**Procedure**

If all measurements of the tests on the first set of samples (100 A test set up):

- either show a disconnection within 5 s during the application of the conditioning voltage

or

- the current through the sample during the application of  $U_{REF}$  after conditioning does not exceed a value of 1 mA,

or

- the current through the sample during the application of  $U_{REF}$  after conditioning does not exceed the initial value determined at  $U_{REF}$  before the test by more than 20 %

no further test is performed.

**8.3.5.3.2** *Modify in the pass criteria the 2<sup>nd</sup> bullet of the exception as follows:*

**Pass Criteria**

SPDs where the current is interrupted or no significant current flows during the application of  $U_{REF}$ .

**8.3.5.3.2** *Add the note after the text "where no disconnection occurs"*

**Pass criteria**

NOTE Significant current means that the current through the sample during the application of  $U_{REF}$  after conditioning does not exceed a value of 1 mA or does not exceed the initial value determined at  $U_{REF}$  before the test by more than 20 %.

**8.4.2.1.1** *Remove column "American Wire Gauge"*

**Table 11**

**8.4.3** *Modify pass criteria to read:*

**Pass criteria**

The air clearances and creepage distances shall not be smaller than the values indicated in Table 15 and Table 16, whereby Table 16 shall be applied to items 1), 2) and 3) according to Table 15.

**8.4.3** *Move footnote <sup>a</sup> from first column  $U_{max}$  to second column  $\leq 2\ 000V$*

**Table 15**

**8.6.1.1**

**Table 19**

*Remove column AWG/MCM*

**8.6.1.1** *Modify the pass criteria text to read:*

The pass criteria **C**, **F** and **G** according to Table 4 and the following additional pass criteria shall apply.

**8.6.1.2** *Replace* "If a maximum overcurrent protection is specified by the manufacturer, the SPD shall be loaded for 1 h with a current equal to k times that maximum overcurrent protection. The factor k shall be selected from Table 20."

by

"If an external maximum overcurrent protection is specified by the manufacturer, the SPD shall be loaded for 1 h with a current equal to 1,6 times the rated current of that maximum overcurrent protection."



**8.6.1.2**  
**Table 20**  
**Annex A,**  
**Table A.1**

*Delete* Table 20 but *keep* the numbering (add void)

*Replace* Table A.1 by

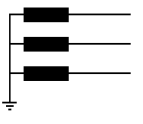
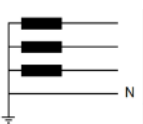
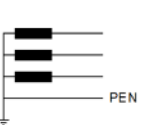
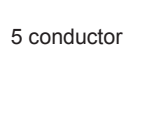
**Table A.1 — Reference test voltage values**

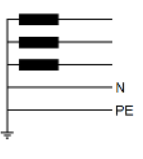
Power distribution system		Nominal AC system Voltage[V] L-PE(N) / L-L	Expected voltage regulation of the power distribution system max+(%)	Reference test voltage $U_{REF}$ [V] (depending on the mode of protection)			
				L-N (PEN)	L-PE	L-L	N-PE
Three phase TT-system without PE and Neutral distribution 	3 conductor	$U_{L-PE}/U_{L-L}$	Tol	---	$(1+Tol/100) \cdot U_{L-PE}$	$(1+Tol/100) \cdot U_{L-L}$	---
	e.g.						
Three phase TT-system with Neutral distribution 	4 conductor	$U_{L-PE}/U_{L-L}$	Tol	$(1+Tol/100) \cdot U_{L-PE}$	$(1+Tol/100) \cdot U_{L-PE}$	$(1+Tol/100) \cdot U_{L-L}$	$(1+Tol/100) \cdot U_{L-PE}$
	e.g.						
Three phase TN-C-system with PEN-distribution 	4 conductor	$U_{L-PE}/U_{L-L}$	Tol	$(1+Tol/100) \cdot U_{L-PE}$	$(1+Tol/100) \cdot U_{L-PE}$	$(1+Tol/100) \cdot U_{L-L}$	---
	e.g.						
Three phase TN-S-system with PE and Neutral distribution 	5 conductor	$U_{L-PE}/U_{L-L}$	Tol	$(1+Tol/100) \cdot U_{L-PE}$	$(1+Tol/100) \cdot U_{L-PE}$	$(1+Tol/100) \cdot U_{L-L}$	$(1+Tol/100) \cdot U_{L-PE}$

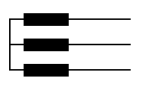
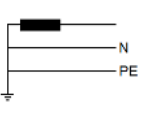
Power distribution system	Nominal AC system Voltage[V] L-PE(N) / L-L	Expected voltage regulation of the power distribution system max+(%)	Reference test voltage $U_{REF}$ [V] (depending on the mode of protection)				
			L-N (PEN)	L-PE	L-L	N-PE	
							
e.g.	230 / 400	10	255	255	440	255	
Three phase IT-system with Neutral distribution 	$U_{L-N}/U_{L-L}$	Tol	$(1+Tol/100) \cdot U_{L-N}$	$(1+Tol/100) \cdot U_{L-L}$	$(1+Tol/100) \cdot U_{L-L}$	$(1+Tol/100) \cdot U_{L-N}$	
e.g.	230 / 400	10	255	440	440	255	
Three phase IT-system without Neutral distribution 	$---/U_{L-L}$	Tol	---	$(1+Tol/100) \cdot U_{L-L}$	$(1+Tol/100) \cdot U_{L-L}$	---	
e.g.	$---/230$	10	---	255	255	---	
Single-phase TN-S-system 	$U_{L-PE}/---$	Tol	$(1+Tol/100) \cdot U_{L-PE}$	$(1+Tol/100) \cdot U_{L-PE}$	---	$(1+Tol/100) \cdot U_{L-PE}$	
e.g.	230/---	10	255	255	---	255	

NOTE: If higher voltage regulation is required for certain applications (for example + 15 %), subject to a special agreement between the manufacturer and the user.

**Annex B** Remove Table B.2 and Table B.3 and text related to B.2 and B.3.

**Annex B, B.1** Modify as follows:

For specific applications with conditions different from the ones given in Table B.1, the TOV test values  $U_T$  and the testing duration may be defined by agreement between the manufacturer and the user, depending on actual network configurations and conditions. The values of  $U_T$  and the corresponding duration(s) shall be declared on the SPDs data sheet according to 7.1.1 c1).

**Annex D Table D.1** Add in sequence 1 after thermal stability : <sup>c</sup>

- Annex D  
Table D.1**      *Replace the test description in test sequence 7 "For SPDs classified outdoor" to read:*  
Environmental tests for outdoor SPDs
- Annex ZA**      *Add Annex ZA (See annexes)*
- Annex ZB**      *Add Annex ZB (See annexes)*
- Bibliography**      *Add the following references:*  
EN 60068-2-6, *Environmental testing – Part 2-6: Tests – Test Fc: Vibration (sinusoidal) (IEC 60068-2-6)*  
EN 60068-2-27, *Environmental testing – Part 2-27: Tests – Test Ea and guidance: Shock IEC 60068-2-27)*  
EN 60068-2-64, *Environmental testing – Part 2-64: Tests – Test Fh: Vibration, broadband random and guidance (IEC 60068-2-64)*  
EN 60721-3-3, *Classification of environmental conditions – Part 3: Classification of groups of environmental parameters and their severities – Section 3: Stationary use at weather protected locations (IEC 60721-3-3)*  
EN 61373, *Railway applications – Rolling stock equipment – Shock and vibration tests (IEC 61373)*  
HD 60364-5-534, *Low-voltage electrical installations – Part 5-53: Selection and erection of electrical equipment – Isolation, switching and control – Clause 534: Devices for protection against overvoltages (IEC 60364-5-53:2001/A1 (CLAUSE 534))*

Add the following annexes:

## Annex ZA (normative)

### Normative references to international publications with their corresponding European publications

The following documents, in whole or in part, are normatively referenced in this document and are indispensable for its application. For dated references, only the edition cited applies. For undated references, the latest edition of the referenced document (including any amendments) applies.

NOTE When an international publication has been modified by common modifications, indicated by (mod), the relevant EN/HD applies.

<u>Publication</u>	<u>Year</u>	<u>Title</u>	<u>EN/HD</u>	<u>Year</u>
IEC 60060-1 + corr. March + corr. March	1989 1990 1992	High-voltage test techniques - Part 1: General definitions and test requirements	HD 588.1 S1 <sup>1)</sup>	1991
IEC 60112	-	Method for the determination of the proof and the comparative tracking indices of solid insulating materials	EN 60112	-
IEC 60529	-	Degrees of protection provided by enclosures (IP Code)	EN 60529	-
IEC 60664-1	2007	Insulation coordination for equipment within low-voltage systems - Part 1: Principles, requirements and tests	EN 60664-1	2007
IEC 60695-2-11 + corr. January	2000 2001	Fire hazard testing - Part 2-11: Glowing/hot-wire based test methods - Glow-wire flammability test method for end- products	EN 60695-2-11	2001
IEC 61000	series	Electromagnetic compatibility (EMC)	EN 61000	series
IEC 61180-1	-	High-voltage test techniques for low-voltage equipment - Part 1: Definitions, test and procedure requirements	EN 61180-1	-

1) HD 588.1 S1 is superseded by EN 60060-1:2010, which is based on IEC 60060-1:2010.

## **Annex ZB** (informative)

### **Vibration and shock test**

#### **ZB.1 General**

This annex gives information if the manufacturer declares performances for vibration and shock conditions.

#### **ZB.2 Vibration and shock test**

##### **ZB.2.1 General**

Vibration and shock tests shall be performed according to

- EN 60068-2-6 for sinusoidal vibration test,
- EN 60068-2-64 for broadband random vibration test, and
- EN 60068-2-27 for shock test.

##### **ZB.2.2 Transportation**

Usually SPDs within their packaging are subjected to mechanical stress due to transportation. This should be checked by a vibration and shock test in accordance with EN 60721-3-2.

##### **ZB.2.3 Special applications**

Special applications of SPDs may require additional vibration and shock tests, on the device itself.

Typical values can be found in EN 60721-3-3. The typical values can be as shown in Table ZB.1.

**Table ZB.1 — Typical Vibration and shock test parameters for various environments**

Environment	EN 60721-3-3 references	Sinusoidal vibrations	Shock	Random Vibrations
Commercial building	3M3	0,75 mm 0,2g FT 8 Hz 1-150 Hz 5 cycles	5g 6ms	NA
Industrial	3M4	3,5 mm 1g FT 8,5 Hz 1-150 Hz 10 cycles	15g 11ms	15g 6ms 100/axe/sens
Severe industrial	3M5	3,5 mm 1g FT 8,5 Hz 1-150 Hz 10 cycles	30g 6ms	25g 6ms 100/axe/sens
Hard	3M6	7,5 mm 2g FT 8 Hz 1-150 Hz 10 cycles	30g 6ms	25g 6ms 100/axe/sens
Extreme	3M8	15 mm 5g FT 9 Hz 1-150 Hz 5 cycles	30g 6ms	25g 6ms 100/axe/sens

Furthermore other applications like railway may require different parameters that are given in corresponding standards or directly from application. For instance required parameters for railway vibration and shock tests are given in EN 61373.

During the sinusoidal and random vibration tests (if requested), the sample should be powered under  $U_c$  with a short circuit capability of at least 5A.

### **ZB.3 Pass criteria**

Pass criteria C, D, E, G and I according to Table 4 shall apply.

## CONTENTS

INTRODUCTION.....	9
1 Scope.....	10
2 Normative references .....	10
3 Terms, definitions and abbreviations .....	10
3.1 Terms and definitions .....	11
3.2 Abbreviations .....	16
4 Service conditions .....	18
4.1 Frequency .....	18
4.2 Voltage.....	18
4.3 Air pressure and altitude .....	18
4.4 Temperatures .....	18
4.5 Humidity.....	18
5 Classification.....	18
5.1 Number of ports .....	18
5.1.1 One .....	18
5.1.2 Two .....	18
5.2 SPD design .....	18
5.2.1 Voltage switching .....	18
5.2.2 Voltage limiting .....	18
5.2.3 Combination .....	18
5.3 Class I, II and III tests .....	18
5.4 Location .....	19
5.4.1 Indoor.....	19
5.4.2 Outdoor .....	19
5.5 Accessibility .....	19
5.5.1 Accessible .....	19
5.5.2 Inaccessible .....	19
5.6 Mounting method.....	19
5.6.1 Fixed .....	19
5.6.2 Portable.....	19
5.7 Disconnectors (including overcurrent protection) .....	19
5.7.1 Location .....	19
5.7.2 Protection functions.....	19
5.8 Degree of protection provided by enclosures .....	19
5.9 Temperature and humidity range .....	20
5.9.1 Normal .....	20
5.9.2 Extended.....	20
5.10 Power system.....	20
5.10.1 AC between 47 Hz and 63 Hz .....	20
5.10.2 AC other than the range of 47 Hz to 63 Hz .....	20
5.11 Multipole SPD .....	20
5.12 SPD failure behaviour .....	20
5.12.1 open circuit (standard type SPD) .....	20
5.12.2 short-circuit (short-circuiting type SPD) .....	20

6	Preferred values for SPD	20
6.1	Preferred values of impulse discharge current $I_{imp}$ for class I tests	20
6.2	Preferred values of nominal discharge current for class II tests $I_n$	20
6.3	Preferred values of open-circuit voltage for class III tests $U_{oc}$	20
6.4	Preferred values of voltage protection level $U_p$	20
6.5	Preferred values of r.m.s. maximum continuous operating voltage $U_c$	20
7	Requirements	21
7.1	General requirements	21
7.1.1	Identification	21
7.1.2	Marking	22
7.2	Electrical requirements	22
7.2.1	Protection against direct contact	22
7.2.2	Residual current $I_{pE}$	23
7.2.3	Voltage protection level $U_p$	23
7.2.4	Operating duty	23
7.2.5	Disconnectors and status indicators	23
7.2.6	Insulation resistance	24
7.2.7	Dielectric withstand	24
7.2.8	Behaviour under Temporary Overvoltages	24
7.3	Mechanical requirements	25
7.3.1	Mounting	25
7.3.2	Screws, current carrying parts and connections	25
7.3.3	External connections	25
7.3.4	Air clearances and creepage distances	27
7.3.5	Mechanical strength	27
7.4	Environmental and material requirements	27
7.4.1	Protection provided by enclosure (IP code)	27
7.4.2	Heat resistance	27
7.4.3	Fire resistance	27
7.4.4	Tracking resistance	27
7.4.5	Electromagnetic compatibility	28
7.5	Additional requirements for specific SPD designs	28
7.5.1	Two port SPDs and one port SPDs with separate input/output terminals	28
7.5.2	Environmental tests for outdoor SPDs	28
7.5.3	SPDs with separate isolated circuits	28
7.5.4	Short-circuiting type SPDs	29
7.6	Additional requirements as may be declared by the manufacturer	29
7.6.1	One-port and two-port SPDs	29
7.6.2	Two port SPDs only	29
8	Type tests	29
8.1	General testing procedures	30
8.1.1	Impulse discharge current used for class I additional duty test	36
8.1.2	Current impulse used for class I and class II residual voltage and operating duty tests	36
8.1.3	Voltage impulse used for class I and II sparkover tests	37
8.1.4	Combination wave used for class III tests	37
8.2	Indelibility of markings	40
8.3	Electrical tests	40

8.3.1	Protection against direct contact.....	40
8.3.2	Residual current $I_{PE}$ .....	40
8.3.3	Measured limiting voltage.....	41
8.3.4	Operating duty test.....	44
8.3.5	Disconnectors and safety performance of overstressed SPDs.....	48
8.3.6	Insulation resistance.....	54
8.3.7	Dielectric withstand.....	55
8.3.8	Behaviour under Temporary Overvoltages (TOVs).....	56
8.4	Mechanical tests.....	60
8.4.1	Reliability of screws, current-carrying parts and connections.....	60
8.4.2	Terminals for external conductors.....	61
8.4.3	Verification of air clearances and creepage distances.....	65
8.4.4	Mechanical strength.....	68
8.5	Environmental and material tests.....	72
8.5.1	Resistance to ingress of solid objects and to harmful ingress of water.....	72
8.5.2	Heat resistance.....	72
8.5.3	Ball pressure test.....	73
8.5.4	Resistance to abnormal heat and fire.....	74
8.5.5	Tracking resistance.....	75
8.6	Additional tests for specific SPD designs.....	75
8.6.1	Test for two-port SPDs and one-port SPDs with separate input/output terminals.....	75
8.6.2	Environmental tests for outdoor SPDs.....	78
8.6.3	SPDs with separate isolated circuits.....	78
8.6.4	Short-circuiting type SPDs.....	78
8.7	Additional tests for specific performance if declared by the manufacturer.....	78
8.7.1	Total discharge current test for multipole SPDs.....	78
8.7.2	Test to determine the voltage drop.....	79
8.7.3	Load-side surge withstand capability.....	79
8.7.4	Measurement of voltage rate of rise $du/dt$ .....	80
9	Routine and acceptance tests.....	80
9.1	Routine tests.....	80
9.2	Acceptance tests.....	80
Annex A (normative)	Reference test voltages for SPDs $U_{REF}$ .....	81
Annex B (normative)	TOV Ratings.....	86
Annex C (normative)	Tests to determine the presence of a switching component and the magnitude of the follow current.....	89
Annex D (normative)	Reduced test procedures.....	91
Annex E (informative)	Alternative circuits for testing SPDs under TOVs caused by faults in the high (medium) voltage system.....	93
Annex F (informative)	Environmental tests for outdoor SPDs.....	94
Annex G (normative)	Temperature rise limits.....	96
Bibliography	.....	97
Figure 1	– Metallic screen test set-up.....	31
Figure 2	– Example of a decoupling network for single-phase power.....	39
Figure 3	– Example of a decoupling network for three-phase power.....	39
Figure 4	– Alternate test for the measured limiting voltage.....	39

Figure 5 – Flow chart of testing to check the voltage protection level $U_p$ .....	42
Figure 6 – Flow chart of the operating duty test .....	45
Figure 7 – Test set-up for operating duty test.....	46
Figure 8 – Operating duty test timing diagram for test classes I and II .....	47
Figure 9 – Additional duty test timing diagram for test class I.....	48
Figure 10 – Operating duty test timing diagram for test class III .....	48
Figure 11 – Test circuit for SPD with $I_{fi}$ lower than the declared short-circuit rating.....	52
Figure 12 – Test circuit for SPD's failure mode simulation .....	53
Figure 13 – Timing diagram for SPD's failure mode simulation.....	53
Figure 14 – Example of a test circuit to perform the test under TOVs caused by faults in the low voltage system.....	57
Figure 15 – Timing diagram for the test under TOVs caused by faults in the low voltage system.....	57
Figure 16 – Example of circuit for testing SPDs for use in TT systems under TOVs caused by faults in high (medium) voltage system .....	59
Figure 17 – Timing diagram for use in testing SPDs under TOVs caused by faults in the high (medium) voltage system using circuit of Figure 16 .....	60
Figure 18 – Test apparatus for impact test.....	69
Figure 19 – Striking element of the pendulum hammer.....	70
Figure 20 – Ball thrust tester.....	73
Figure 21 – Loading rod for ball thrust tester.....	73
Figure 22 – Examples for appropriate test circuits of the load side short-circuit test(s).....	77
Figure E.1 – Examples of a three-phase and single-phase circuit for use in testing SPDs under TOVs caused by faults in the high (medium) voltage system .....	93
Table 1 – List of Abbreviations.....	17
Table 2 – Class I, II and III tests .....	19
Table 3 – Type test requirements for SPDs.....	32
Table 4 – Common pass criteria for type tests .....	34
Table 5 – Cross reference for pass criteria versus type tests .....	35
Table 6 – Preferred parameters for class I test .....	36
Table 7 – Tests to be performed to determine the measured limiting voltage .....	43
Table 8 – Prospective short-circuit current and power factor .....	50
Table 9 – Dielectric withstand .....	55
Table 10 – Screw thread diameters and applied torques .....	61
Table 11 – Cross-sections of copper conductors for screw-type or screwless terminals .....	62
Table 12 – Pulling forces (screw terminals).....	63
Table 13 – Conductor dimensions .....	63
Table 14 – Pulling forces (screwless terminals) .....	64
Table 15 – Air clearances for SPDs .....	66
Table 16 – Creepage distances for SPDs.....	67
Table 17 – Relationship between material groups and classifications.....	68
Table 18 – Fall distances for impact requirements .....	71
Table 19 – Test conductors for rated load current test .....	75

Table 20 – Current factor $k$ for overload behaviour .....	76
Table 21 – Tolerances for proportional surge currents .....	79
Table A.1 – Reference test voltage values .....	82
Table B.1 – TOV test values for systems complying with IEC 60364 series .....	86
Table B.2 – TOV test parameters for North American systems .....	87
Table B.3 – TOV test parameters for Japanese systems .....	88
Table D.1 – Reduced test procedure for SPDs complying with IEC 61643-1:2005 .....	92
Table G.1 – Temperature-rise limits .....	96

## INTRODUCTION

This part of IEC 61643 addresses safety and performance tests for surge protective devices (SPDs).

There are three classes of tests:

The Class I test is intended to simulate partial conducted lightning current impulses. SPDs subjected to Class I test methods are generally recommended for locations at points of high exposure, e.g., line entrances to buildings protected by lightning protection systems.

SPDs tested to Class II or III test methods are subjected to impulses of shorter duration.

SPDs are tested on a “black box” basis as far as possible.

IEC 61643-12 addresses the selection and application principles of SPDs in practical situations.

## LOW-VOLTAGE SURGE PROTECTIVE DEVICES –

### Part 11: Surge protective devices connected to low-voltage power systems – Requirements and test methods

#### 1 Scope

This part of IEC 61643 is applicable to devices for surge protection against indirect and direct effects of lightning or other transient overvoltages. These devices are packaged to be connected to 50/60 Hz a.c. power circuits, and equipment rated up to 1 000 V r.m.s. Performance characteristics, standard methods for testing and ratings are established. These devices contain at least one nonlinear component and are intended to limit surge voltages and divert surge currents.

#### 2 Normative references

The following referenced documents are indispensable for the application of this document. For dated references, only the edition cited applies. For undated references, the latest edition of the referenced document (including any amendments) applies.

IEC 60060-1:1989, *High-voltage test techniques – Part 1: General definitions and test requirements*

IEC 60112, *Method for the determination of the proof and the comparative tracking indices of solid insulating materials*

IEC 60529, *Degrees of protection provided by enclosures (IP Code)*

IEC 60664-1:2007, *Insulation coordination for equipment within low-voltage systems – Part 1: Principles, requirements and tests*

IEC 60695-2-11:2000, *Fire hazard testing – Part 2-11: Glowing/hot-wire based test methods – Glow-wire flammability test method for end-products*

IEC 61000 (all parts), *Electromagnetic compatibility (EMC)*

IEC 61180-1, *High-voltage test techniques for low voltage equipment – Part 1: Definitions, test and procedure requirements*

#### 3 Terms, definitions and abbreviations

For the purposes of this document, the following terms, definitions and abbreviations apply.

### 3.1 Terms and definitions

#### 3.1.1

##### **surge protective device**

##### **SPD**

device that contains at least one nonlinear component that is intended to limit surge voltages and divert surge currents

NOTE An SPD is a complete assembly, having appropriate connecting means.

#### 3.1.2

##### **one-port SPD**

SPD having no intended series impedance

NOTE A one port SPD may have separate input and output connections.

#### 3.1.3

##### **two-port SPD**

SPD having a specific series impedance connected between separate input and output connections

#### 3.1.4

##### **voltage switching type SPD**

SPD that has a high impedance when no surge is present, but can have a sudden change in impedance to a low value in response to a voltage surge

NOTE Common examples of components used in voltage switching type SPDs are spark gaps, gas tubes and thyristors. These are sometimes called "crowbar type" components.

#### 3.1.5

##### **voltage limiting type SPD**

SPD that has a high impedance when no surge is present, but will reduce it continuously with increased surge current and voltage

NOTE Common examples of components used in voltage limiting type SPDs are varistors and avalanche breakdown diodes. These are sometimes called "clamping type" components.

#### 3.1.6

##### **combination type SPD**

SPD that incorporates both, voltage switching components and voltage limiting components. The SPD may exhibit voltage switching, limiting or both

#### 3.1.7

##### **short-circuiting type SPD**

SPD tested according to Class II tests which changes its characteristic to an intentional internal short-circuit due to a surge current exceeding its nominal discharge current  $I_n$

#### 3.1.8

##### **mode of protection of an SPD**

an intended current path, between terminals that contains protective components, e.g. line-to-line, line-to-earth, line-to-neutral, neutral-to-earth.

#### 3.1.9

##### **nominal discharge current for class II test**

$I_n$

crest value of the current through the SPD having a current waveshape of 8/20

**3.1.10**  
**impulse discharge current for class I test**

$I_{\text{imp}}$   
crest value of a discharge current through the SPD with specified charge transfer  $Q$  and specified energy  $W/R$  in the specified time

**3.1.11**  
**maximum continuous operating voltage**

$U_{\text{C}}$   
maximum r.m.s. voltage, which may be continuously applied to the SPD's mode of protection

NOTE The  $U_{\text{C}}$  value covered by this standard may exceed 1 000 V.

**3.1.12**  
**follow current**

$I_{\text{f}}$   
peak current supplied by the electrical power system and flowing through the SPD after a discharge current impulse

**3.1.13**  
**rated load current**

$I_{\text{L}}$   
maximum continuous rated r.m.s. current that can be supplied to a resistive load connected to the protected output of an SPD

**3.1.14**  
**voltage protection level**

$U_{\text{p}}$   
maximum voltage to be expected at the SPD terminals due to an impulse stress with defined voltage steepness and an impulse stress with a discharge current with given amplitude and waveshape

NOTE The voltage protection level is given by the manufacturer and may not be exceeded by:

- the measured limiting voltage, determined for front-of-wave sparkover (if applicable) and the measured limiting voltage, determined from the residual voltage measurements at amplitudes corresponding to  $I_{\text{n}}$  and/or  $I_{\text{imp}}$  respectively for test classes II and/or I;
- the measured limiting voltage at  $U_{\text{OC}}$ , determined for the combination wave for test class III.

**3.1.15**  
**measured limiting voltage**

highest value of voltage that is measured across the terminals of the SPD during the application of impulses of specified waveshape and amplitude

**3.1.16**  
**residual voltage**

$U_{\text{res}}$   
crest value of voltage that appears between the terminals of an SPD due to the passage of discharge current

**3.1.17**  
**temporary overvoltage test value**

$U_{\text{T}}$   
test voltage applied to the SPD for a specific duration  $t_{\text{T}}$ , to simulate the stress under TOV conditions

**3.1.18**  
**load-side surge withstand capability for a two-port SPD**

ability of a two-port SPD to withstand surges on the output terminals originating in circuitry downstream of the SPD

**3.1.19**  
**voltage rate-of-rise of a two-port SPD**

rate of change of voltage with time measured at the output terminals of a two port SPD under specified test conditions

**3.1.20**  
**1,2/50 voltage impulse**

voltage impulse with a nominal virtual front time of 1,2  $\mu\text{s}$  and a nominal time to half-value of 50  $\mu\text{s}$

NOTE The Clause 6 of IEC 60060-1 (1989) defines the voltage impulse definitions of front time, time to half-value and waveshape tolerance.

**3.1.21**  
**8/20 current impulse**

current impulse with a nominal virtual front time of 8  $\mu\text{s}$  and a nominal time to half-value of 20  $\mu\text{s}$

NOTE The Clause 8 of IEC 60060-1 (1989) defines the current impulse definitions of front time, time to half-value and waveshape tolerance.

**3.1.22**  
**combination wave**

a wave characterized by defined voltage amplitude ( $U_{OC}$ ) and waveshape under open-circuit conditions and a defined current amplitude ( $I_{CW}$ ) and waveshape under short-circuit conditions

NOTE The voltage amplitude, current amplitude and waveform that is delivered to the SPD are determined by the combination wave generator (CWG) impedance  $Z_f$  and the impedance of the DUT.

**3.1.23**  
**open circuit voltage**

$U_{OC}$   
open circuit voltage of the combination wave generator at the point of connection of the device under test

**3.1.24**  
**combination wave generator short-circuit current**

$I_{CW}$   
prospective short-circuit current of the combination wave generator, at the point of connection of the device under test

NOTE When the SPD is connected to the combination wave generator, the current that flows through the device is generally less than  $I_{CW}$ .

**3.1.25**  
**thermal stability**

SPD is thermally stable if, after heating up during the operating duty test, its temperature decreases with time while energized at specified maximum continuous operating voltage and at specified ambient temperature conditions

**3.1.26**  
**degradation (of performance)**

undesired permanent departure in the operational performance of equipment or a system from its intended performance

**3.1.27**  
**short-circuit current rating**

$I_{SCCR}$   
maximum prospective short-circuit current from the power system for which the SPD, in conjunction with the disconnecter specified, is rated

### 3.1.28

#### **SPD disconnecter (disconnecter)**

device for disconnecting an SPD, or part of an SPD, from the power system

NOTE This disconnecting device is not required to have isolating capability for safety purposes. It is to prevent a persistent fault on the system and is used to give an indication of an SPD's failure. Disconnectors can be internal (built in) or external (required by the manufacturer). There may be more than one disconnector function, for example an over-current protection function and a thermal protection function. These functions may be in separate units.

### 3.1.29

#### **degree of protection of enclosure**

##### **IP**

classification preceded by the symbol IP indicating the extent of protection provided by an enclosure against access to hazardous parts, against ingress of solid foreign objects and possibly harmful ingress of water

### 3.1.30

#### **type test**

conformity test made on one or more items representative of the production

[IEC 60050-151:2001, 151-16-16]

### 3.1.31

#### **routine test**

test made on each SPD or on parts and materials as required to ensure that the product meets the design specifications

[IEC 60050-151:2001, 151-16-17, modified]

### 3.1.32

#### **acceptance tests**

contractual test to prove to the customer that the item meets certain conditions of its specification

[IEC 60050-151:2001, 151-16-23]

### 3.1.33

#### **decoupling network**

an electrical circuit intended to prevent surge energy from being propagated to the power network during energized testing of SPDs

NOTE This electrical circuit is sometimes called a "back filter".

### 3.1.34

#### **Impulse test classification**

##### **3.1.34.1**

###### **class I tests**

tests carried out with the impulse discharge current  $I_{imp}$ , with an 8/20 current impulse with a crest value equal to the crest value of  $I_{imp}$ , and with a 1,2/50 voltage impulse

##### **3.1.34.2**

###### **class II tests**

tests carried out with the nominal discharge current  $I_n$ , and the 1,2/50 voltage impulse

##### **3.1.34.3**

###### **class III tests**

tests carried out with the 1,2/50 voltage - 8/20 current combination wave generator

### 3.1.35

#### **residual current device**

#### **RCD**

switching device or associated devices intended to cause the opening of the power circuit when the residual or unbalance current attains a given value under specified conditions

### 3.1.36

#### **sparkover voltage of a voltage switching SPD**

#### **trigger voltage of a voltage switching SPD**

maximum voltage value at which the sudden change from high to low impedance starts for a voltage switching SPD

### 3.1.37

#### **specific energy for class I test**

#### **$W/R$**

energy dissipated by a unit resistance of  $1 \Omega$  with the impulse discharge current  $I_{imp}$

NOTE This is equal to the time integral of the square of the current ( $W/R = \int i^2 dt$ ).

### 3.1.38

#### **prospective short-circuit current of a power supply**

#### **$I_p$**

current which would flow at a given location in a circuit if it were short-circuited at that location by a link of negligible impedance

NOTE This prospective symmetrical current is expressed by its rms value.

### 3.1.39

#### **follow current interrupt rating**

#### **$I_{fi}$**

prospective short-circuit current that an SPD is able to interrupt without operation of a disconnector

### 3.1.40

#### **residual current**

#### **$I_{PE}$**

current flowing through the PE terminal of the SPD while energized at the reference test voltage ( $U_{REF}$ ) when connected according to the manufacturer's instructions

### 3.1.41

#### **status indicator**

device that indicates the operational status of an SPD, or a part of an SPD.

NOTE Such indicators may be local with visual and/or audible alarms and/or may have remote signalling and/or output contact capability.

### 3.1.42

#### **output contact**

contact included in a circuit separate from the main circuit of an SPD, and linked to a disconnector or status indicator

### 3.1.43

#### **multipole SPD**

type of SPD with more than one mode of protection, or a combination of electrically interconnected SPDs offered as a unit

**3.1.44****total discharge current** **$I_{\text{Total}}$** 

current which flows through the PE or PEN conductor of a multipole SPD during the total discharge current test

NOTE 1 The aim is to take into account cumulative effects that occur when multiple modes of protection of a multipole SPD conduct at the same time.

NOTE 2  $I_{\text{Total}}$  is particularly relevant for SPDs tested according to test class I, and is used for the purpose of lightning protection equipotential bonding according to IEC 62305 series.

**3.1.45****reference test voltage** **$U_{\text{REF}}$** 

r.m.s. value of voltage used for testing which depends on the mode of protection of the SPD, the nominal system voltage, the system configuration and the voltage regulation within the system

NOTE The reference test voltage is selected from Annex A based on the information given by the manufacturer according to 7.1.1 b8).

**3.1.46****transition surge current rating for short-circuiting type SPD** **$I_{\text{trans}}$** 

8/20 impulse current value exceeding the nominal discharge current  $I_n$ , that will cause a short-circuiting type SPD to short-circuit

**3.1.47****Voltage for clearance determination** **$U_{\text{max}}$** 

highest measured voltage during surge applications according 8.3.3 for clearance determination

**3.1.48****maximum discharge current** **$I_{\text{max}}$** 

crest value of a current through the SPD having an 8/20 waveshape and magnitude according to the manufacturers specification.  $I_{\text{max}}$  is equal to or greater than  $I_n$

**3.2 Abbreviations**

The Table 1 below provides the list of abbreviations used in this standard.

**Table 1 – List of Abbreviations**

Abbreviation	Description	Definition/clause
<b>General abbreviations</b>		
ABD	avalanche breakdown device	7.2.5.2
CWG	combination wave generator	3.1.22
RCD	residual current device	3.1.35
DUT	device under test	General
IP	degree of protection of enclosure	3.1.29
TOV	temporary overvoltage	General
SPD	surge protective device	3.1.1
$k$	trip current factor for overload behaviour	Table 20
$Z_f$	fictive impedance (of combination wave generator)	8.1.4 c)
$W/R$	specific energy for class I test	3.1.37
$T1$ , $T2$ , and/or $T3$	product marking for test classes I, II and/or III	7.1.1
$t_T$	TOV application time for testing	3.1.17
<b>Abbreviations related to voltage</b>		
$U_C$	maximum continuous operating voltage	3.1.11
$U_{REF}$	Reference test voltage	3.1.45
$U_{OC}$	open circuit voltage of the combination wave generator	3.1.22, 3.1.23
$U_p$	voltage protection level	3.1.14
$U_{res}$	residual voltage	3.1.16
$U_{max}$	voltage for clearance determination	3.1.47
$U_T$	temporary overvoltage test value	3.1.17
<b>Abbreviations related to current</b>		
$I_{imp}$	impulse discharge current for class I test	3.1.10
$I_{max}$	maximum discharge current	3.1.48
$I_n$	nominal discharge current for class II test	3.1.9
$I_f$	follow current	3.1.12
$I_{fi}$	follow current interrupt rating	3.1.39
$I_L$	rated load current	3.1.13
$I_{CW}$	short-circuit current of the combination wave generator	3.1.24
$I_{SCCR}$	short-circuit current rating	3.1.27
$I_P$	prospective short-circuit current of the power supply	3.1.38
$I_{PE}$	residual current at $U_{REF}$	3.1.40
$I_{Total}$	total discharge current for multipole SPD	3.1.44
$I_{trans}$	transition surge current rating for short-circuiting type SPD	3.1.46

## 4 Service conditions

### 4.1 Frequency

Frequency range is from 47 Hz to 63 Hz a.c.

### 4.2 Voltage

The voltage applied continuously between the terminals of the surge protective device (SPD) must not exceed its maximum continuous operating voltage  $U_C$ .

### 4.3 Air pressure and altitude

Air pressure is 80 kPa to 106 kPa. These values represent an altitude of +2 000 m to -500 m, respectively.

### 4.4 Temperatures

- normal range: –5 °C to +40 °C

NOTE This range addresses SPDs for indoor use in weather-protected locations having neither temperature nor humidity control and corresponds to the characteristics of external influences code AB4 in IEC 60364-5-51.

- extended range: –40 °C to +70 °C

NOTE This range addresses SPDs for outdoor use in non weather protected locations.

### 4.5 Humidity

- normal range: 5 % to 95 %

NOTE This range addresses SPDs for indoor use in weather-protected locations having neither temperature nor humidity control and corresponds to the characteristics of external influences code AB4 in IEC 60364-5-51.

- extended range: 5 % to 100 %

NOTE This range addresses SPDs for outdoor use in non weather protected locations.

## 5 Classification

The manufacture shall classify the SPDs in accordance with the following parameters.

### 5.1 Number of ports

#### 5.1.1 One

#### 5.1.2 Two

### 5.2 SPD design

#### 5.2.1 Voltage switching

#### 5.2.2 Voltage limiting

#### 5.2.3 Combination

### 5.3 Class I, II and III tests

Information required for class I, class II and class III tests is given in Table 2.

**Table 2 – Class I, II and III tests**

Tests	Required information	Test procedures (see subclauses)
Class I	$I_{imp}$	8.1.1; 8.1.2; 8.1.3
Class II	$I_n$	8.1.2; 8.1.3
Class III	$U_{oc}$	8.1.4; 8.1.4.1

## 5.4 Location

### 5.4.1 Indoor

SPDs intended for use in enclosures and/or inside buildings or shelters.

SPDs installed in outdoor enclosures or shelters are considered for indoor use.

### 5.4.2 Outdoor

SPDs intended for use without enclosures and outside of buildings or shelters (e.g. on low voltage overhead lines).

## 5.5 Accessibility

### 5.5.1 Accessible

An SPD which can be fully or partly touched by an unskilled person, without the use of a tool to open any covers or enclosures, once installed.

### 5.5.2 Inaccessible

An SPD which cannot be touched by an unskilled person either due to being mounted out of reach (e.g. mounted on overhead lines) or due to being located within enclosures which can only be opened by using a tool, once installed.

## 5.6 Mounting method

### 5.6.1 Fixed

### 5.6.2 Portable

## 5.7 Disconnectors (including overcurrent protection)

### 5.7.1 Location

#### 5.7.1.1 Internal

#### 5.7.1.2 External

#### 5.7.1.3 Both (internal and external)

### 5.7.2 Protection functions

#### 5.7.2.1 Thermal

#### 5.7.2.2 Leakage current

#### 5.7.2.3 Overcurrent

## 5.8 Degree of protection provided by enclosures

According to IP code of IEC 60529.

**5.9 Temperature and humidity range****5.9.1 Normal****5.9.2 Extended****5.10 Power system****5.10.1 AC between 47 Hz and 63 Hz****5.10.2 AC other than the range of 47 Hz to 63 Hz**

This may require additional and/or modified test procedures.

**5.11 Multipole SPD****5.12 SPD failure behaviour****5.12.1 open circuit (standard type SPD)****5.12.2 short-circuit (short-circuiting type SPD)****6 Preferred values for SPD**

NOTE Preferred values means values which are often used in practice. Depending on real conditions lower and in some cases higher values may be needed.

**6.1 Preferred values of impulse discharge current  $I_{imp}$  for class I tests**

$I_{imp}$	1;	2;	5;	10;	12,5;	20	and 25 kA
Q	0,5;	1;	2,5;	5;	6,25;	10	and 12,5 As
W/R	0,25;	1,0;	6,25;	25;	39;	100	and 156 kJ/Ω

**6.2 Preferred values of nominal discharge current for class II tests  $I_n$** 

0,05; 0,1; 0,25; 0,5; 1,0; 1,5; 2,0; 2,5; 3,0; 5,0; 10; 15 and 20 kA

**6.3 Preferred values of open-circuit voltage for class III tests  $U_{oc}$** 

0,1; 0,2; 0,5; 1; 2; 3; 4; 5; 6; 10 and 20 kV

**6.4 Preferred values of voltage protection level  $U_p$** 

0,08; 0,09; 0,10; 0,12; 0,15; 0,22; 0,33; 0,4; 0,5; 0,6; 0,7; 0,8; 0,9;  
1,0; 1,2; 1,5; 1,8; 2,0; 2,5; 3,0; 4,0; 5,0; 6,0; 8,0 and 10 kV

**6.5 Preferred values of r.m.s. maximum continuous operating voltage  $U_c$** 

45; 52; 63; 75; 85; 95; 110; 130; 150; 175; 220; 230; 240;  
255; 260; 275; 280; 320; 335; 350; 385; 400; 420; 440; 460; 510  
530; 600; 635; 660; 690; 800; 900; 1 000; 1 500; 1 800 and 2 000 V

## 7 Requirements

### 7.1 General requirements

#### 7.1.1 Identification

The following information shall be provided by the manufacturer.

#### **Markings which are mandatory on the body, or permanently attached to the body, of the SPD:**

- a1) Manufacturer's name or trademark and model number
- a2) Maximum continuous operating voltage  $U_c$  (one value for each mode of protection)
- a3) Type of current: a.c. or “~” and/or frequency
- a4) Test classification and discharge parameters shall be printed next to each other for each mode of protection declared by the manufacturer:

For test class I:

either “test class I” and “ $I_{imp}$ ” and the value in kA,  
and/or “T1” (T1 in a square) and “ $I_{imp}$ ” and the value in kA

For test class II:

either “test class II” and “ $I_n$ ” and the value in kA,  
and/or “T2” (T2 in a square) and “ $I_n$ ” and the value in kA

For test class III:

either “test class III” and “ $U_{oc}$ ” and the value in kV,  
and/or “T3” (T3 in a square) and “ $U_{oc}$ ” and the value in kV.

- a5) Voltage protection level  $U_p$  (one value for each mode of protection)
- a6) Degree of protection provided by the enclosure (IP code) if >IP20
- a7) Identification of terminals or leads (if not otherwise identified on the devices)
- a8) Rated load current  $I_L$  for two port SPDs and for one port SPDs with separate input and output terminals.

Where space does not allow all the above markings to be placed, the manufacturer's name or trademark and model number is sufficient on the SPD; other remaining required markings shall appear on the installation instruction.

An SPD may be classified according to more than one test class (e.g. test class I (T1) and test class II (T2)). In this case, the tests required for all declared test classes shall be performed. If in such case the manufacturer declares only one protection level, the highest protection level shall appear in the marking.

#### **Information which shall be provided with the products to be delivered:**

- b1) Location (See 5.4)
- b2) Number of ports
- b3) Method of mounting
- b4) Short-circuit current rating  $I_{SCCR}$  (exemptions see 7.2.5.3)
- b5) Ratings and characteristics for external disconnectors, if required.
- b6) Indication of disconnector operation (if any)
- b7) Orientation for normal installation, if significant
- b8) Installation instructions
  - type of LV systems (TN-system, TT-system, IT-system)

- intended connection (line to neutral, line to ground, neutral to ground, line to line)
  - nominal a.c. system voltages and maximum allowed voltage regulation for which the SPD is designed, mechanical dimensions, lead lengths, etc.
- b9) Temperature and humidity range (see 4.4 and 4.5)
- b10) Follow current interrupt rating  $I_{fi}$  (except in the case of voltage-limiting SPDs)
- b11) Residual current  $I_{PE}$
- b12) Transition surge current rating for short-circuiting type SPD  $I_{trans}$
- b13) The minimum distance from any earthed conductive surface at which the SPD can be installed
- b14)  $I_{MAX}$ , (optional).

**Information which shall be available in a product datasheet:**

- c1) Temporary overvoltage rating  $U_T$  and/or the type(s) of power system(s) the SPD is designed for according to Annex B and corresponding connection details
- c2) Total discharge current  $I_{Total}$  for multipole SPDs (if declared by the manufacturer) and the corresponding test class
- c3) Voltage drop for two port SPDs
- c4) Load-side surge withstand capability for two-port SPDs (if declared by the manufacturer)
- c5) Information about replaceable parts (indicators, fuses, etc. if applicable)
- c6) Voltage rate of rise  $du/dt$  (if declared by the manufacturer)
- c7) Current factor  $k$ , if different from Table 20
- c8) Modes of protection (for SPDs with more than one mode of protection)

**Information which shall be provided by the manufacturer for type testing:**

- d1) Presence of switching component(s) (see Annex C)
- d2) Follow current to be expected during preconditioning test ( $\leq 500$  A or  $> 500$  A - see Annex C)
- d3) If the status indication circuitry does not use certified components operated within their ratings, the manufacturer shall provide the appropriate testing standards for the specific component to allow it to be tested.
- d4) Isolation and dielectric withstand of separate isolated circuits
- d5) prospective short-circuit current for conditioning according 8.3.5.3.2

Compliance is checked by visual inspection.

### 7.1.2 Marking

Markings on the device shall be indelible and legible and shall not be placed on screws or removable parts.

NOTE A plug-in SPD module is not considered a removable part.

Compliance is checked by the test in accordance with 8.2.

## 7.2 Electrical requirements

### 7.2.1 Protection against direct contact

These requirements are valid for accessible SPDs where the maximum continuous operating voltage  $U_C$  is above 50 V r.m.s.

For protection against direct contact (inaccessibility of live parts), SPDs shall be designed in such a way that live parts cannot be touched when the SPD is installed for the intended use.

SPDs, except SPDs classified for mounting out-of-reach-only, shall be so designed that, when they are wired and mounted as for normal use, live parts are not accessible, even after removal of parts which can be removed without the use of a tool.

The connection between the earthing terminals and all accessible parts connected thereto shall be of low resistance.

Compliance is checked by the tests according IEC 60529 and according 8.3.1.

### **7.2.2 Residual current $I_{PE}$**

For all SPDs with a terminal for the protective conductor, the residual current  $I_{PE}$  shall be measured when all SPD terminals are connected to a power supply at the reference test voltage ( $U_{REF}$ ) according to the manufacturer's instructions.

Compliance is checked by the test according 8.3.2

### **7.2.3 Voltage protection level $U_p$**

The measured limiting voltage of the SPDs shall not exceed the voltage protection level that is specified by the manufacturer.

Compliance is checked by the test in accordance with 8.3.3.

### **7.2.4 Operating duty**

The SPD shall be capable of withstanding specified discharge currents during application of the maximum continuous operating voltage  $U_c$  without unacceptable changes in its characteristics.

Compliance is checked by the test in accordance with 8.3.4.

### **7.2.5 Disconnectors and status indicators**

#### **7.2.5.1 Disconnectors**

The SPD shall have disconnectors (which can be either internal, external or both), except SPDs for connection N-PE in TN and/or TT systems only. Their operation shall be indicated by a corresponding status indicator.

The required behaviour of the disconnectors during and after various type tests is given in Table 3.

Table 3 provides information on the inclusion of disconnectors during the various type tests. The required behaviour of disconnectors during and after various type tests is given by pass criteria **F**, **G**, **H** and **J** of Table 4, and is checked by the tests in accordance with 8.3.5.

#### **7.2.5.2 Thermal protection**

SPDs shall be protected against overheating due to degradation or overstress.

This test is not performed on SPDs containing only voltage switching components and/or ABD devices.

Compliance is checked by the test in accordance with 8.3.5.2.

### 7.2.5.3 Short-circuit current behaviour

An SPD shall fail without causing a hazardous condition or withstand the prospective short-circuit currents of the power system that may occur during an SPD failure.

Compliance is checked by the test in accordance with 8.3.5.3, 8.3.5.3.1 and 8.3.5.3.2.

The test according 8.3.5.3.1 is only performed if the declared follow current interrupt rating  $I_{fi}$  is smaller than the test current.

These tests are not performed on SPDs classified for outdoor use and for mounting out of reach and for SPDs for connection N-PE in TN and/or TT systems only.

### 7.2.5.4 Status indicators

The manufacturer shall provide information about the function of the indicator and the actions to be taken after change of status indication.

A status indicator may be composed of two parts (one of which is not replaced on replacement of the SPD), linked by a coupling mechanism which can be mechanical, optical, audio, electromagnetic, etc. The part of the status indicator which is not replaced shall be capable of operating at least 50 times.

NOTE The action of the coupling mechanism which operates the non-replaced part of the status indicator may be simulated by means other than operation of the section within the replaced part of the SPD, e.g. a separate electromagnet or a spring.

Where there is an appropriate standard for the type of indication used, this shall be met by the non-replaced part of the status indicator, with the exception that the indicator need only be tested for 50 operations.

### 7.2.6 Insulation resistance

The insulation resistance of the SPD shall be sufficient with respect to leakage currents and protection against direct contact.

Compliance is checked by the test in accordance with 8.3.6.

### 7.2.7 Dielectric withstand

The dielectric withstand of the SPD shall be sufficient with respect to insulation breakdown and protection against direct contact.

Compliance is checked by the test in accordance with 8.3.7.

### 7.2.8 Behaviour under temporary overvoltages

An SPD shall pass the TOV-tests according 8.3.8.1 and 8.3.8.2 and shall fulfil the pass criteria according to the relevant tables in Annex B and according 8.3.8.1 and 8.3.8.2.

NOTE 1 The tests given in 8.3.8.1 and 8.3.8.2 do not take into account the possibility of a surge occurring simultaneously with a TOV event.

SPD shall withstand the overvoltages caused by faults or disturbances in the high voltage system or fail in manner not creating a hazard.

SPDs, for which the manufacturer declares in his installation instructions that they may be installed in TT-systems between neutral and PE upstream the main RCD, shall pass the TOV withstand mode criteria given 8.3.8.2.

NOTE 2 This covers the application described in 534.2.3.3 of IEC 60364-5-53.

### **7.2.8.1 TOVs caused by faults or disturbances in the low voltage system**

For SPDs with a  $U_C$  greater than or equal to  $U_T$  there is no need to perform this test.

This test shall be performed in accordance with 8.3.8.1.

### **7.2.8.2 TOVs caused by faults in the high (medium) voltage system**

For SPDs with a  $U_C$  greater than or equal to  $U_T$  there is no need to perform this test.

Compliance is checked by the test in accordance with 8.3.8.2.

## **7.3 Mechanical requirements**

### **7.3.1 Mounting**

SPDs shall be provided with appropriate means for mounting that will ensure mechanical stability.

Mechanical coding/interlock shall be provided to prevent incorrect combinations of plug-in SPD modules and sockets.

Compliance is checked by visual inspection.

### **7.3.2 Screws, current carrying parts and connections**

Compliance is accordance with 8.4.1 and checked by inspection and trial mounting.

### **7.3.3 External connections**

Electrical connections shall be possible using one of the following means:

- screw terminals and bolted connections;
- screwless terminals;
- insulation piercing connections;
- flat quick connect terminations;
- flying leads;
- other equally effective means;

or

- standardised plugs and/or sockets.

The following requirements do not apply to standardised plugs and/or sockets:

Terminals shall be designed for the connection of cables having a minimum and a maximum cross-sectional area according to 8.4.2.

Terminals shall be fastened to the SPD in such a way that they will not work loose if the clamping screws or the lock nuts are tightened or loosened. A tool shall be required to loosen the clamping screws or the lock nuts.

- a) Terminals for external conductors shall be such that the conductors may be connected so as to ensure that the necessary contact pressure is maintained permanently. The terminals shall be readily accessible under the intended conditions of use.

- b) The means for clamping the conductors in the terminals shall not serve to fix any other component, although they may hold the terminals in place or prevent them from turning.
- c) Terminals shall have adequate mechanical strength.
- d) Terminals shall be so designed that they clamp the conductor without undue damage to the conductor.
- e) Terminals shall be so designed that they clamp the conductor reliably and between metal surfaces.
- f) Terminals shall be so designed or positioned that neither a rigid solid conductor nor a wire of a stranded conductor can slip out while the clamping screws or nuts are tightened.

#### 7.3.3.1 Screw terminals

- a) Screws and nuts for clamping the conductors shall have a metric ISO thread or a thread comparable in pitch and mechanical strength.

NOTE SI, BA and UN threads may be used as they are virtually equivalent in pitch and mechanical strength to metric ISO threads.

- b) Terminals shall be so fixed or located that, when the clamping screws or nuts are tightened or loosened, the terminals shall not work loose from their fixings to the SPDs.

These requirements do not imply that the terminals shall be so designed that their rotation or displacement is prevented, but any movement shall be sufficiently limited so as to prevent non-compliance with the requirements of this standard.

The use of sealing compound or resin is considered to be sufficient for preventing a terminal from working loose, provided that:

- the sealing compound or resin is not subject to stress during normal use, and
- the effectiveness of the sealing compound or resin is not impaired by temperatures attained by the terminal under the least favourable conditions specified in this standard.
- c) Clamping screws or nuts of terminals intended for the connection of protective conductors shall be adequately secured against accidental loosening.
- d) Screws shall not be made of metal that is soft or liable to creep, such as zinc or aluminium

Compliance is checked by inspection and by the tests in accordance with 8.4.2.1.

#### 7.3.3.2 Screwless terminals

Terminals shall be so designed and constructed that:

- a) each conductor is clamped individually. During the connection or disconnection the conductors can be connected or disconnected either at the same time or separately,
- b) it is possible to clamp securely any number of conductors up to the maximum provided.

Compliance is checked by inspection and by the tests in accordance with 8.4.2.2.

#### 7.3.3.3 Insulation piercing connections

Compliance is checked by inspection and by the tests in accordance with 8.4.2.3.

#### 7.3.3.4 Flat quick connect terminations

Compliance is checked by inspection and by the tests in accordance with 8.4.2.4 (under consideration).

#### **7.3.3.5 Pigtail connections (flying leads)**

Compliance is checked by inspection and by the tests in accordance with 8.4.2.5.

#### **7.3.3.6 Standardised plugs and/or socket outlets**

Plugs and socket outlets shall correspond to the relevant international or national requirements (e.g. IEC 60884-1, IEC 60320-series).

#### **7.3.4 Air clearances and creepage distances**

The SPD shall have sufficient air clearances and creepage distances.

Compliance is checked by the test in accordance with 8.4.3.

#### **7.3.5 Mechanical strength**

All parts of the SPD relating to the protection against direct contact shall have sufficient mechanical strength.

Compliance is checked by the test in accordance with 8.4.4.

### **7.4 Environmental and material requirements**

SPDs shall operate satisfactorily under the service conditions specified in accordance with Clause 4.

#### **7.4.1 Protection provided by enclosure (IP code)**

SPDs shall be provided with an enclosure for protection against ingress of solid objects and water in accordance with the IP code declared by the manufacturer.

Compliance is checked by inspection and by the tests in accordance with 8.5.1.

#### **7.4.2 Heat resistance**

SPDs shall be sufficiently resistant to heat.

Compliance is checked by the tests in accordance with 8.3.5.1, 8.5.2 and 8.5.3.

#### **7.4.3 Fire resistance**

Insulating parts of the housing shall be either non-flammable or self-extinguishing.

Compliance is checked by the test in accordance with 8.5.4.

#### **7.4.4 Tracking resistance**

The tracking index of insulating materials, which may create a conductive path between electrical connections, are checked by the test in accordance with 8.5.5.

Testing is not necessary if the creepage distances are greater or equal to double the values indicated in 8.4.3 or in case of insulating materials made out of ceramic, mica or similar materials.

## **7.4.5 Electromagnetic compatibility**

### **7.4.5.1 Electromagnetic immunity**

SPDs either incorporating no electronic circuits or incorporating electronic circuits in which all components are passive (for example diodes, resistors, capacitors, inductors, varistors and other surge protective components) are not sensitive to electromagnetic disturbances expected under normal service conditions and therefore no immunity tests are required. For SPDs containing sensitive electronic circuits, refer to IEC 61000 series.

### **7.4.5.2 Electromagnetic emission**

For SPDs not incorporating electronic circuits, or incorporating electronic circuits that do not generate fundamental frequencies greater than 9 kHz in normal operation, electromagnetic disturbances can only be generated during protective operations. The duration of these disturbances is in the order of microseconds to milliseconds.

The frequency, level and the consequences of these emissions are considered as part of the normal electromagnetic environment of low-voltage installations. Therefore, the requirements for electromagnetic emissions are deemed to be satisfied and no verification is necessary.

For SPDs containing electronic circuits that perform a switching function operating at a frequency of 9 kHz or greater, refer to IEC 61000 series.

## **7.5 Additional requirements for specific SPD designs**

### **7.5.1 Two port SPDs and one port SPDs with separate input/output terminals**

#### **7.5.1.1 Rated load current $I_L$**

The manufacturer shall declare the rated load current.

Compliance is checked by the test in accordance with 8.6.1.1.

#### **7.5.1.2 Overload behaviour**

The SPD shall not be damaged or altered by overloads, which may occur in normal use.

Compliance with this requirement is checked according to 8.6.1.2.

#### **7.5.1.3 Load-side short-circuit rating**

The SPD shall be able to carry the currents caused by a power short-circuit on the load side until it is interrupted either by the SPD itself or by an internal or external disconnecter.

Compliance is checked by the test in accordance with 8.6.1.3.

### **7.5.2 Environmental tests for outdoor SPDs**

Outdoor SPDs shall be sufficiently resistant to UV radiation and corrosion.

For proposed test procedures refer to 8.6.2 and Annex F.

### **7.5.3 SPDs with separate isolated circuits**

Where a SPD includes a circuit that is electrically isolated from the main circuit, the manufacturer shall provide information about the isolation and dielectric withstand voltages between the circuits as well as the relevant standards that the manufacturer is claiming conformity with.

Where there are more than two circuits, declarations shall be made with regard to each combination of circuits.

The isolation and dielectric withstand between the main circuits and separate isolated circuits shall be tested according to 8.3.6 and 8.3.7.

#### **7.5.4 Short-circuiting type SPDs**

These SPDs shall be capable of withstanding a short-circuit current test at their declared short-circuit current rating after having been overstressed by a surge current according to their transition surge rating  $I_{trans}$ .

Compliance is checked in accordance with 8.6.4

### **7.6 Additional requirements as may be declared by the manufacturer**

#### **7.6.1 One-port and two-port SPDs**

##### **7.6.1.1 Total Discharge Current $I_{Total}$ (for multipole SPDs)**

This test is only conducted if the manufacturer claims a total discharge current. Compliance is checked in accordance with 8.7.1.

#### **7.6.2 Two port SPDs only**

##### **7.6.2.1 Voltage drop**

The voltage drop shall be checked in accordance with 8.7.2.

##### **7.6.2.2 Load-side surge withstand capability**

If the manufacturer declares a load-side surge withstand capability then compliance is checked in accordance with 8.7.3.

##### **7.6.2.3 Voltage rate of rise $du/dt$**

If the manufacturer declares a  $du/dt$  value for a two port SPD containing a filtering device, this value shall be tested in accordance with 8.7.4.

## **8 Type tests**

Type tests are carried out as indicated in Table 3 on three samples per test sequence. Within any test sequence, the tests shall be carried out in the order given in Table 3. The order in which test sequence are carried out may be varied. Test on terminals shall be performed on three terminal samples for each construction/terminal type. (An SPD with at least three identical terminals fulfils this sample requirement).

A sample has passed a test sequence of Table 3 if all the requirements of the relevant test clauses and the relevant pass criteria are fulfilled.

If all required samples pass a test sequence, the design of the SPD is acceptable for that test sequence. If two or more test samples fail a test sequence, the SPD does not comply with this standard.

In the event that a single sample does not pass a test, this test, and those preceding in the same test sequence that may have influenced the result of this test, shall be repeated with three new samples, but this time no failure of any sample is allowed.

A set of three samples may be used for more than one test sequence, if agreed by the manufacturer.

NOTE For short-circuit current behaviour according 8.3.5.3 special prepared samples are required.

If the SPD is an integral part of a product covered by another standard, the requirements of the other standard shall apply to those parts of the product, which do not belong to the SPD section of the product. The SPD section shall comply with the general (7.1), the electrical (7.2), the environmental and material (7.4) requirements of this document. The mechanical requirements of other standards shall also be applied to the SPD.

### 8.1 General testing procedures

If not otherwise specified, the reference standard for high voltage test procedures is IEC 61180-1.

Unless otherwise specified, a.c. values given in this standard are r.m.s. values.

The SPD shall be mounted and electrically connected in accordance with the manufacturer's installation procedures. Neither external cooling nor heating shall be employed.

When not otherwise specified, the test shall be performed in free air and the ambient temperature shall be  $20\text{ °C} \pm 15\text{ °C}$ .

If not otherwise specified, for all tests where a power supply at  $U_{REF}$  or  $U_C$  is required, the voltage tolerance for testing shall be  $\begin{matrix} 0 \\ -5 \end{matrix}$  %.

When testing SPDs for which the manufacturer supplies integral cables, the full length of those cables shall form part of the SPD under test.

If not otherwise specified, during the test, no maintenance or dismantling of the SPD is allowed. External disconnectors shall be selected according to the manufacturer's instructions and connected for testing if required according to Table 3.

All tests shall be performed on each mode of protection declared by the manufacturer, however, if some modes of protection have identical circuitry, one single test can be performed on the mode of protection which presents the most vulnerable configuration, using new samples each time.

For multimode devices (e.g. 3 phase SPD) in which the protective component circuitry is identical, the testing of each of the modes (e.g. three phases) can fulfil the three sample requirement.

For SPDs with a designated N terminal which may be applied in systems without distributed neutral according to the manufacturers instructions, separate testing is required for the L-PE mode of protection with the neutral being unconnected.

If the use of tissue paper is required according to Table 3:

- For fixed SPDs: tissue paper shall be fixed at a distance of  $100\text{ mm} \pm 20\text{ mm}$  in all directions of the sample, except the mounting surface.
- For portable SPDs: tissue paper shall be wrapped loosely around on all sides of the SPD including the bottom side.

If required according to Table 3, a metallic screen shall be located adjacent to all sides of the SPD at the minimum distance specified in 7.1.1 b13). Details, including distances of the

metallic screen from the SPD, shall be stated in the test report. The characteristics of the metallic screen shall be as follows:

- Structure:
  - Woven wire mesh
  - Perforated metal or expanded metal
- Ratio hole area/total area: 0,45-0,65
- Size of hole not exceeding 30 mm<sup>2</sup>
- Finish: bare or conductive plating
- Resistance: The resistance between the furthest point of the metallic screen and the connection point of the metallic screen shall be sufficiently low not to limit the short-circuit current of the screen circuit

The metallic screen shall be connected via a 6A gL/gG fuse to one of the SPD terminals under test (Figure 1). The connection of the screen shall be changed to the other SPD-terminal after each short-circuit application.

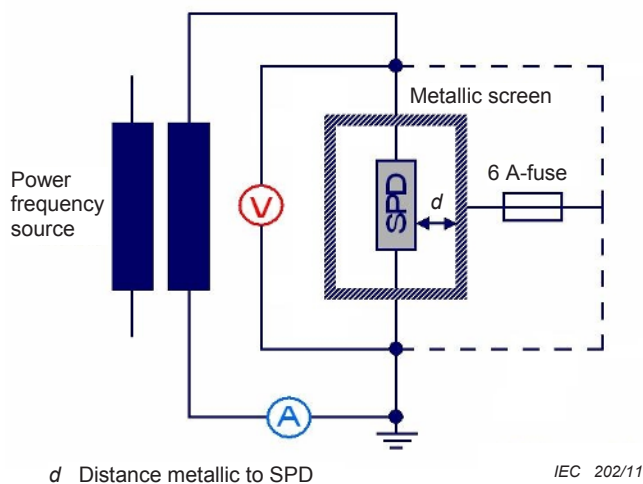

**Figure 1 – Metallic screen test set-up**

If the manufacturer sets different requirements for the external disconnector(s) depending upon the prospective short-circuit current of the supply system, all relevant test sequences shall be performed for every combination of required disconnector(s) and corresponding prospective short-circuit currents.

Throughout the entire type testing procedure, the status shown by the indicator(s) shall give a clear sign of the status of the part to which it is linked. Where there is more than one method of status indication, for example local and remote indication, each type of indication shall be checked.

It should be noted that good testing techniques are required for impulse testing and measurements. This is needed to ensure that correct test values are measured and recorded.

SPDs shall not create any hazard when operated under the test conditions in accordance with this standard.

Table 3 – Type test requirements for SPDs

Test sequence	Test description	Subclause requirement/test	External disconnectors connected <sup>a</sup>	Tissue paper used	Metallic screen used	Test class I	Test class II	Test class III
1	Identification and marking	7.1.1/7.1.2/8.2	-	-	-	A	A	A
	Mounting	7.3.1	-	-	-	A	A	A
	Terminals and connections	7.3.2/7.3.3/8.4.2	-	-	-	A	A	A
	Testing for protection against direct contact	7.2.1/8.3.1	-	-	-	A	A	A
	Environment, IP code	7.4.1 / 8.5.1	-	-	-	A	A	A
	Residual current	7.2.2 / 8.3.2	-	-	-	A	A	A
	Operating duty test	7.2.4/8.3.4 <sup>b</sup>						
	Operating duty test for test classes I, II or III	8.3.4.2 / 8.3.4.3/ 8.3.4.5	A	-	-	A	A	A
	Additional duty test for test class I	8.3.4.4	A	-	-	A	-	-
	Thermal stability	7.2.5.2 / 8.3.5.2	A	-	-	A	A	A
	Air clearances and creepage distances	7.3.4 / 8.4.3	-	-	-	A	A	A
	Ball pressure test	7.4.2 / 8.5.3	-	-	-	A	A	A
	Resistance to abnormal heat and fire	7.4.3 / 8.5.4	-	-	-	A	A	A
Tracking resistance	7.4.4 / 8.5.5	-	-	-	A	A	A	
2	Voltage protection level	7.2.3/8.3.3						
	Residual voltage	8.3.3.1	-	-	-	A	A	-
	Front of wave sparkover voltage	8.3.3.2	-	-	-	A	A	-
	Limiting voltage with combination wave	8.3.3.3	-	-	-	-	-	A
2a	See below - only if applicable							
2b	See below - only if applicable							
3	Insulation resistance	7.2.6 / 8.3.6	-	-	-	A	A	A
	Dielectric withstand	7.2.7 / 8.3.7	-	-	-	A	A	A
3a	See below - only if applicable							
	Mechanical strength	7.3.5 / 8.4.4	-	-	-	A	A	A
	Temperature withstand	7.2.5 / 8.3.5.1 <sup>b</sup>	-	-	-	A	A	A
3b <sup>c</sup>	See below - only if applicable							
3c	See below - only if applicable							
4 <sup>c</sup>	Heat resistance	7.4.2 / 8.5.2	-	-	-	A	A	A
	TOV tests	7.2.8 / 8.3.8						
	TOVs caused by faults or disturbances in the low voltage system	7.2.8.1/8.3.8.1 <sup>b</sup>	A	A	-	A	A	A
	TOVs caused by faults in the high (medium) voltage system	7.2.8.2/8.3.8.2 <sup>b</sup>	A	A	-	A	A	A
5 <sup>c</sup>	Short-circuit current behaviour	7.2.5.3 / 8.3.5.3	A	-	A	A	A	A

**Table 3 – Type test requirements for SPDs (continued)**

<b>Additional tests for specific SPD designs</b>								
Test sequence	Test description	Subclause requirement/test	External disconnectors connected <sup>a</sup>	Tissue paper used	Metallic screen used	Test class I	Test class II	Test class III
<b>Additional tests for two-port SPDs and one port-SPDs with separate input / output terminals</b>								
<b>3c<sup>c</sup></b>	Rated load current	7.5.1.1 / 8.6.1.1	A	-	-	A	A	A
	Overload behaviour	7.5.1.2 / 8.6.1.2 <sup>b</sup>	-	-	-	A	A	A
<b>2b</b>	Load side short-circuit current behaviour	7.5.1.3 / 8.6.1.3 <sup>b</sup>	A	-	A	A	A	A
<b>Additional tests if declared by the manufacturer</b>								
<b>3b</b>	Voltage drop	7.6.2.1 / 8.7.2	-	-	-	A	A	A
<b>2a<sup>c</sup></b>	Load side surge withstand	7.6.2.2 / 8.7.3 <sup>b</sup>	A	-	-	A	A	A
<b>6</b>	Total discharge current test for multipole SPDs	7.6.1.1 / 8.7.1 <sup>b</sup>	-	-	-	A	A	-
<b>Additional tests for outdoor use SPDs</b>								
<b>7</b>	For SPDs classified "outdoor"	7.5.2 / 8.6.2	-	O	-	A	A	-
<b>Additional tests for SPDs with separate isolated circuits</b>								
<b>3a</b>	Isolation between separate circuits	7.5.3/ 8.3.6 / 8.3.7	-	-	-	A	A	A
<b>Additional tests for short-circuiting type SPDs</b>								
<b>8</b>	Change of characteristic procedure (preconditioning to short-circuited condition)	7.5.4 / 8.6.4	-	-	-	-	A	-
	Surge withstand test (in short-circuited condition)	7.5.4 / 8.6.4	-	-	-	-	A	-
	Short-circuit current behaviour (in short-circuited condition)	7.5.4 / 8.6.4	A	-	A	-	A	-
A = applicable - = not applicable O = optional								
<sup>a</sup> external disconnectors connected means that all disconnectors as specified by the manufacturer shall be tested with the SPD during the type tests, except for RCDs, which are not tested during the operating duty test according to 8.3.4.								
<sup>b</sup> For these tests initial measurements of leakage currents according to Table 4, pass criterion E may be necessary.								
<sup>c</sup> For this test sequence more than one set of samples may be needed.								

**Table 4 – Common pass criteria for type tests**

<b>A</b>	Thermal stability shall be achieved. The SPD is considered to be thermally stable if the crest of the resistive component of the current flowing into the SPD or the power dissipation shows either a decreasing tendency or does not increase during 15 min of $U_C$ voltage application immediately after the application of $U_C$ . If the test itself is performed with the SPD energized at $U_C$ , then $U_C$ either remains applied for these 15 min without interruption or is reapplied within less than 30 s.
<b>B</b>	Voltage and current records and visual inspection shall show no indication of puncture or flashover.
<b>C</b>	No visible damage shall occur during the test. After the test, small indents and cracks not impairing the protection against direct contact are disregarded during this check, unless the degree of protection (IP-code) given for the SPD is no longer provided. There shall be no visual evidence of burning of the sample after the test.
<b>D</b>	Values for measured limiting voltage after the test shall be below or equal to $U_P$ . The measured limiting voltage shall be determined, using the tests described in 8.3.3, but the test of 8.3.3.1 is performed only with a 8/20-surge current with a crest value of $I_{imp}$ for Test Class I or with $I_n$ for Test Class II or with the test of 8.3.3.3 but only at $U_{OC}$ for Test class III.
<b>E</b>	<p>No excessive leakage currents shall occur after the test.</p> <p>The SPD shall be connected as for normal use according to the manufacturer's instructions to a power supply at the reference test voltage (<math>U_{REF}</math>). The current that flows through each terminal is measured. Its resistive component (measured at the crest of the sine wave) shall not exceed a value of 1 mA, or the current shall not have changed by more than 20 % compared to the initial value determined at the beginning of the relevant test sequence.</p> <p>Any resettable or rearmable disconnecter shall be switched off manually, if applicable, and the dielectric withstand shall be checked by application of two times <math>U_C</math> or 1 000 V a.c., whichever is greater. During the test, no flashover, breakdown of insulation either internally (puncture) or externally (tracking) or any other manifestation of disruptive discharge shall occur.</p> <p>In addition for SPD modes connected N-PE only the current through the PE-terminal shall be measured, whereas the terminals are connected to a power supply at the maximum continuous operating voltage (<math>U_C</math>). Its resistive component (measured at the crest of the sine wave) shall not exceed a value of 1 mA, or the current shall not have changed by more than 20 % compared to the initial value determined at the beginning of the relevant test sequence.</p> <p>If there is more than one possible connection arrangement for normal use, this check shall be performed for all arrangements.</p>
<b>F</b>	External disconnectors as specified by the manufacturer shall not operate during the test and shall be in working order after the test. For the purpose of this clause, working order means that there is no damage to the disconnector and that it is still operational. Operation can be checked either manually (where possible) or by a simple electrical test agreed between the manufacturer and the laboratory.
<b>G</b>	Internal disconnectors as specified by the manufacturer shall not operate during the test and shall be in working order after the test. For the purpose of this clause, working order means that there is no damage of the disconnector and that it is still operational. Operation can be checked either manually (where possible) or by a simple electrical test agreed between the manufacturer and the laboratory.
<b>H</b>	Disconnection shall be provided by one or more internal and/or external disconnector(s). Their correct indication shall be checked.
<b>I</b>	SPDs with an IP degree equal to, or greater than, IP20 shall not have live parts accessible with the standardized test finger applied with a force of 5 N (see IEC 60529), except the live parts which were already accessible before the test when the SPD is fitted as in normal use.
<b>J</b>	<p>If disconnection (internal or external) occurs during the test, there shall be clear evidence of effective disconnection of the corresponding protective component(s).</p> <p>If internal disconnection occurs, the test sample is connected as for normal use at the maximum continuous operating voltage <math>U_C</math> and at rated frequency for 1 min. The test source shall have a short-circuit current capability equal or greater than 200 mA. The current that flows through the relevant protective components shall not exceed a value of 1 mA.</p> <p>Currents through components connected in parallel to the relevant protective component(s), or otherwise connected (e.g. indicator circuits), are disregarded for this measurement, as long as they cannot cause a current through the relevant protective component(s).</p> <p>In addition the current through the PE-terminal, including parallel circuits and other circuits (e.g. indicator circuits), if any, shall not exceed 1 mA.</p> <p>If there is more than one possible connection arrangement for normal use, this check shall be performed for all arrangements.</p>
<b>K</b>	The short-circuit current from the power source, if any, shall be interrupted within 5 s by one or more internal and/or external disconnector(s).
<b>L</b>	The tissue paper shall not catch fire.
<b>M</b>	There shall be no explosion or other hazard to either personnel or the facility.
<b>N</b>	There shall be no flashover to the metallic screen and the 6 A gL/gG fuse connecting the screen shall not operate during the test.
<b>O</b>	<p>After completion of this test the samples shall be allowed to return to room temperature and be connected to a power source at <math>U_C</math> for 2 h.</p> <p>The residual current shall be monitored and not exceed the value measured at the beginning of the test by more than 10 %.</p>

**Table 5 – Cross reference for pass criteria versus type tests**

<b>Pass criteria</b> <b>clause</b>	<b>A</b>	<b>B</b>	<b>C</b>	<b>D</b>	<b>E</b>	<b>F</b>	<b>G</b>	<b>H</b>	<b>I</b>	<b>J</b>	<b>K</b>	<b>L</b>	<b>M</b>	<b>N</b>	<b>O</b>
<b>8.3.3.4</b>		A	A						A				A		
<b>8.3.4.6</b>	A	A	A	A	A	A	A						A		
<b>8.3.5.1</b>			A				A								
<b>8.3.5.2</b>			A					A	A	A			A		A
<b>8.3.5.3 a)</b>			A					A	A	A	A		A	A	
<b>8.3.5.3 b)</b>			A					C	A	C	C		A	A	
<b>8.3.5.3.1</b>			A					A	A	A	A		A	A	
<b>8.3.5.3.2</b>			A					C	A	C			A	A	
<b>8.3.8.1 a)</b>			A					A	A	A	A	A	A		
<b>8.3.8.1 b)</b>	A	A	A	A	A	A	A		A			A	A		
<b>8.3.8.2 a)</b>			A					A	A	A	A	A	A		
<b>8.3.8.2 b)</b>	A	A	A	A	A		A		A		A	A	A		
<b>8.5.2</b>			A						A						
<b>8.6.1.1</b>			A			A	A								
<b>8.6.1.2 a)</b>			A					A	A	A			A		
<b>8.6.1.2 b)</b>			A	A	A				A						
<b>8.6.1.3 a)</b>			A		A			A	A	A	A		A	A	
<b>8.6.1.3 b)</b>			A	A	A			A	A	A	A		A	A	
<b>8.6.4.2</b>			A						A				A		
<b>8.6.4.3</b>			A					A	A	A	A		A	A	
<b>8.7.1</b>		A	A	A	A		A		A				A		
<b>8.7.3</b>	A	A	A	A	A	A	A								
A applicable															
C conditionally applicable															

### 8.1.1 Impulse discharge current used for class I additional duty test

The impulse discharge current passing through the device under test (SPD) is defined by the crest value  $I_{imp}$ , the charge  $Q$  and the specific energy  $W/R$ . The impulse current shall show no polarity reversal and shall reach  $I_{imp}$  within 50  $\mu$ s. The transfer of the charge  $Q$  shall occur within 5 ms and the specific energy  $W/R$  shall be dissipated within 5 ms.

The impulse duration shall not exceed 5 ms.

Table 6 gives values of  $Q$  (As) and  $W/R$  (kJ/ $\Omega$ ) for example values of  $I_{imp}$  (kA).

The relationship between  $I_{imp}$ ,  $Q$  and  $W/R$  is as follows:

$$Q = I_{imp} \times a \quad \text{where } a = 5 \times 10^{-4} \text{ s}$$

$$W/R = I_{imp}^2 \times b \quad \text{where } b = 2,5 \times 10^{-4} \text{ s}$$

**Table 6 – Preferred parameters for class I test**

$I_{imp}$ within 50 $\mu$ s kA	$Q$ within 5 ms As	$W/R$ within 5 ms kJ/ $\Omega$
25	12,5	156
20	10	100
12,5	6,25	39
10	5	25
5	2,5	6,25
2	1	1
1	0,5	0,25

NOTE One of the possible test impulses which meet the above parameters is the 10/350 waveshape proposed in IEC 62305-1.

The following tolerances shall apply:

- $I_{imp}$        $-10 \%/+10 \%$ ;
- $Q$              $-10 \%/+20 \%$ ;
- $W/R$          $-10 \%/+45 \%$ .

### 8.1.2 Current impulse used for class I and class II residual voltage and operating duty tests

The waveshape is 8/20. The tolerances on the current waveshape passing through the device under test are as follows:

- crest value       $\pm 10 \%$
- front time         $\pm 10 \%$
- time to half value  $\pm 10 \%$

A small overshoot or oscillation is tolerated provided that the amplitude of any oscillation is not more than 5 % of the crest value. Any polarity reversal after the current has fallen to zero shall not be more than 30 % of the crest value.

In the case of two port devices, the magnitude of the reversal shall be less than 5 %, so that it does not affect the measured limiting voltage.

### 8.1.3 Voltage impulse used for class I and II sparkover tests

The standard voltage waveshape is 1,2/50. The tolerances of the voltage waveshape of the open circuit voltage at the points where the device under test (DUT) will be connected are the following:

- crest value  $\pm 5$  %
- front time  $\pm 30$  %
- time to half value  $\pm 20$  %

Oscillations or overshoot may occur at the crest of the impulse. If the frequency of such oscillations is more than 500 kHz or the duration of the overshoot is less than 1  $\mu$ s, a mean curve shall be drawn and, for the purpose of the measurement, the maximum amplitude of this mean curve defines the measured crest value of the test voltage.

Oscillations exceeding 3 % of the crest value are not allowed on the rising portion of the voltage impulse between 0 % and 80 % of the crest value.

The measuring devices shall have an overall bandwidth of at least 25 MHz and the overshoot shall be less than 3 %.

The short-circuit current of the test generator shall be less than 20 % of the nominal discharge current  $I_n$  of the SPD.

### 8.1.4 Combination wave used for class III tests

The standard impulse of a combination waveform generator is characterized by the output voltage under open-circuit conditions and the output current under short-circuit conditions. The open-circuit voltage shall have a front time of 1,2  $\mu$ s and a time to half value of 50  $\mu$ s. The short-circuit current shall have a front time of 8  $\mu$ s and a time to half value of 20  $\mu$ s.

NOTE 1 For further guidance on this subject see IEEE C62.45:2009

a) The tolerances of the open circuit voltage  $U_{oc}$  at the points where the device under test (DUT) will be connected are as follows:

- crest value  $\pm 5$  %
- front time  $\pm 30$  %
- time to half value  $\pm 20$  %.

These tolerances are for the generator alone, without any SPD or power supply circuit being connected.

Oscillations or overshoot may occur at the crest of the impulse. If the frequency of such oscillations is more than 500 kHz or the duration of the overshoot is less than 1  $\mu$ s, a mean curve shall be drawn and, for the purpose of the measurement, the maximum amplitude of this mean curve defines the measured crest value of the test voltage.

Oscillations exceeding 3 % of the crest value are not allowed on the rising portion of the voltage impulse between 0 % and 80 % of the crest value.

The measuring devices shall have an overall bandwidth of at least 25 MHz and an overshoot of less than 3 %.

b) The tolerances of the short-circuit current  $I_{sc}$  at the points where the device under test (DUT) will be connected are as follows:

- crest value  $\pm 10\%$
- front time  $\pm 10\%$
- time to half value  $\pm 10\%$ .

These generator tolerances shall be met with or without any power supply circuit being connected, depending if the test has to be performed energised or un-energized.

A small overshoot or oscillation is tolerated provided that the amplitude of any oscillation is not more than 5 % of the crest value. Any polarity reversal after the current has fallen to zero shall not be more than 30 % of the crest value.

c) Test setup:

The fictive impedance  $Z_f$  of the generator shall be nominally  $2\ \Omega$ . By definition, the fictive impedance is the ratio of the crest value of the open-circuit voltage  $U_{OC}$  divided by the crest value of the short-circuit current  $I_{SC}$ .

The above waveform and tolerance requirements only apply to the test performed at the value of  $U_{OC}$  declared by the manufacturer, which may require some generator adjustment to achieve. For tests performed below  $U_{OC}$  under clause 8.3.3.3 b), no further generator adjustment is required, and the same settings shall be used.

The generator coupling element shall preferably be realised by a varistor element with a rating as close as possible to the continuous operating voltage  $U_C$  of the device under test, to ensure comparable results among different test laboratories.

NOTE 2 This avoids excessive efforts for test set-ups because of the non-linearity in the generator coupling element which influences the total generator impedance at different settings for  $U_{OC}$ .

The maximum values for crest open-circuit voltage  $U_{OC}$  and crest short-circuit current  $I_{SC}$  are 20 kV and 10 kA respectively. Above these values (20 kV /10 kA), class II tests shall be performed.

The possibility of using decoupling networks for energized testing depends on the internal design of the SPD:

- when the SPD does not contain reactive components, the decoupling network is not required.
- when the SPD contains reactive components, but does not contain any voltage switching components, preferably no decoupling network shall be used or the measured limiting voltage test according 8.3.3 may be performed by using the alternate test procedure according 8.1.4.1.
- when the SPD contains reactive components and voltage switching components, no decoupling network shall be used.

Coupling elements and decoupling networks are only necessary for energised testing.

Examples for decoupling networks are given in Figure 2 and Figure 3.

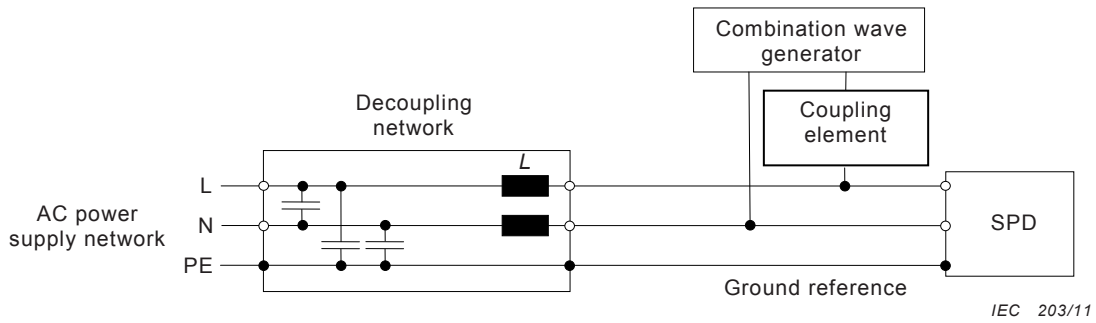

Figure 2 – Example of a decoupling network for single-phase power

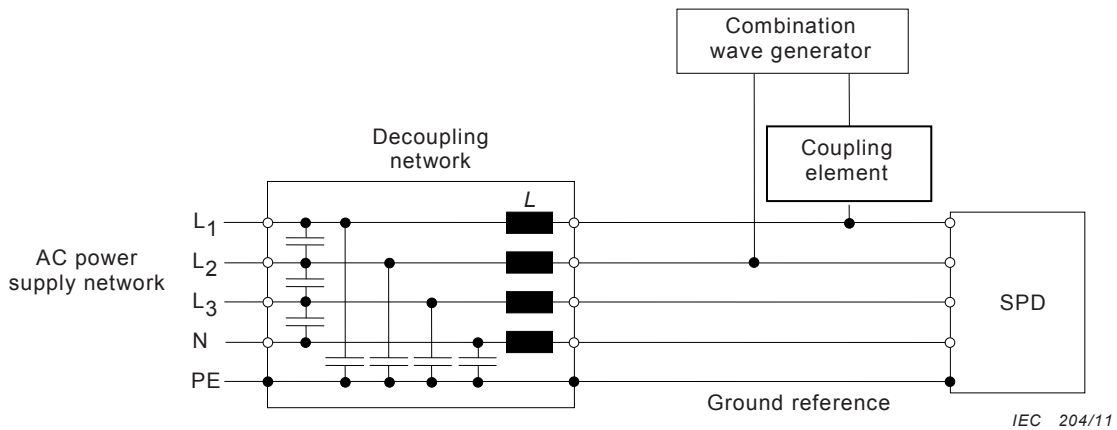

Figure 3 – Example of a decoupling network for three-phase power

8.1.4.1 Alternate test circuit to determine the measured limiting voltage (8.3.3) without a decoupling network

Two-port SPDs with reactive components create interaction with the reactive components of a back filter. This can produce artificially low values of measured limiting voltage. Tests in such cases shall use the alternative test circuit according to Figure 4.

- a) For a.c. rated SPDs a d.c. voltage of  $U_c \cdot \sqrt{2}$ , shall be applied to the SPD via a diode. The impulse shall preferably be applied via a varistor.
- b) The application of the impulse shall occur at  $100 \text{ ms}^{+10}_0\%$  after closure of S<sub>1</sub>. The d.c. voltage shall be disconnected within 10 ms after impulse application.
- c) Reverse polarity tests can be conducted by reversing the SPD connection to the test circuit.

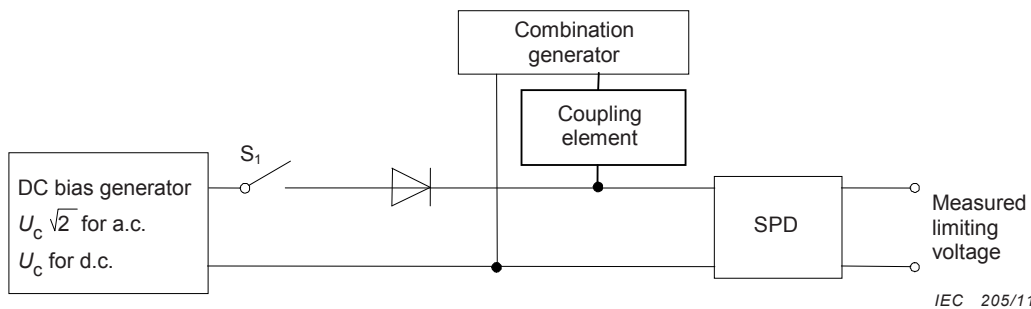

Figure 4 – Alternate test for the measured limiting voltage

## 8.2 Indelibility of markings

This test shall be applied on markings of all types except those made by impressing, molding and engraving.

The test is made by rubbing the marking by hand for 15 s with a piece of cotton soaked with water and again for 15 s with a piece of cotton soaked with aliphatic solvent hexane with a content of aromatics of maximum 0,1 % volume, a kauributanol value of 29, initial boiling-point approximately 65 °C and specific gravity of 0,68 g/cm<sup>3</sup>).

After this test, the marking shall be easily legible.

## 8.3 Electrical tests

### 8.3.1 Protection against direct contact

#### 8.3.1.1 Insulated parts

The sample is mounted as for normal use and the test is conducted using conductors of the smallest cross-sectional area and then again using conductors of the largest cross-sectional area specified in 8.4.2.

The standard test finger (in accordance with IEC 60529) is applied in every possible position.

For plug-in SPDs (which can be changed without a tool), the test finger is applied in every possible position, when the plug is partially inserted or completely inserted in a socket outlet.

An electrical continuity indicator operating from a voltage of not less than 40 V and not more than 50 V, one side of which is connected between the all live terminals of the sample linked together and the other side is connected to the test finger to check for the possibility of contact with any live part of the sample.

#### 8.3.1.2 Metal parts

Metal parts which are accessible when the SPD is wired and mounted as for normal use shall be connected to earth through a low resistance connection, except of small screws and the like, isolated from live parts, for fixing bases and covers or cover plates of socket-outlets.

A current (derived from an a.c. source having a no-load voltage not exceeding 12 V) equal to 1,5 times the rated load current or 25 A, whichever is the greater, is passed between the earthing terminal and each of the accessible metal parts in turn.

The voltage drop between the earthing terminal and the accessible metal part is measured and the resistance is calculated from the current and this voltage drop. The resistance shall not exceed 0,05 Ω.

NOTE Care should be taken that the contact resistance between the tip of the measuring probe and the metal part under test does not influence the test results.

### 8.3.2 Residual current $I_{pE}$

The SPD shall be connected as for normal use according to the manufacturer's instructions. The voltage shall be adjusted to the reference test voltage of ( $U_{REF}$ ).

The residual current flowing through the PE terminal is measured.

NOTE 1 If the manufacturer allows more than one configuration for the SPD installation, this test should be performed for every configuration.

NOTE 2 The true r.m.s. current value should be measured.

NOTE 3 If the SPD contains a terminal which is dedicated to be connected to a PEN conductor only, then this terminal is not considered to be a PE terminal.

### **Pass criteria**

The measured residual current value shall not exceed the value declared by the manufacturer according 7.1.1 b11).

### **8.3.3 Measured limiting voltage**

The tests on the different SPD types to determine their measured limiting voltages shall be performed according to the flow chart in Figure 5 and the following Table 7.

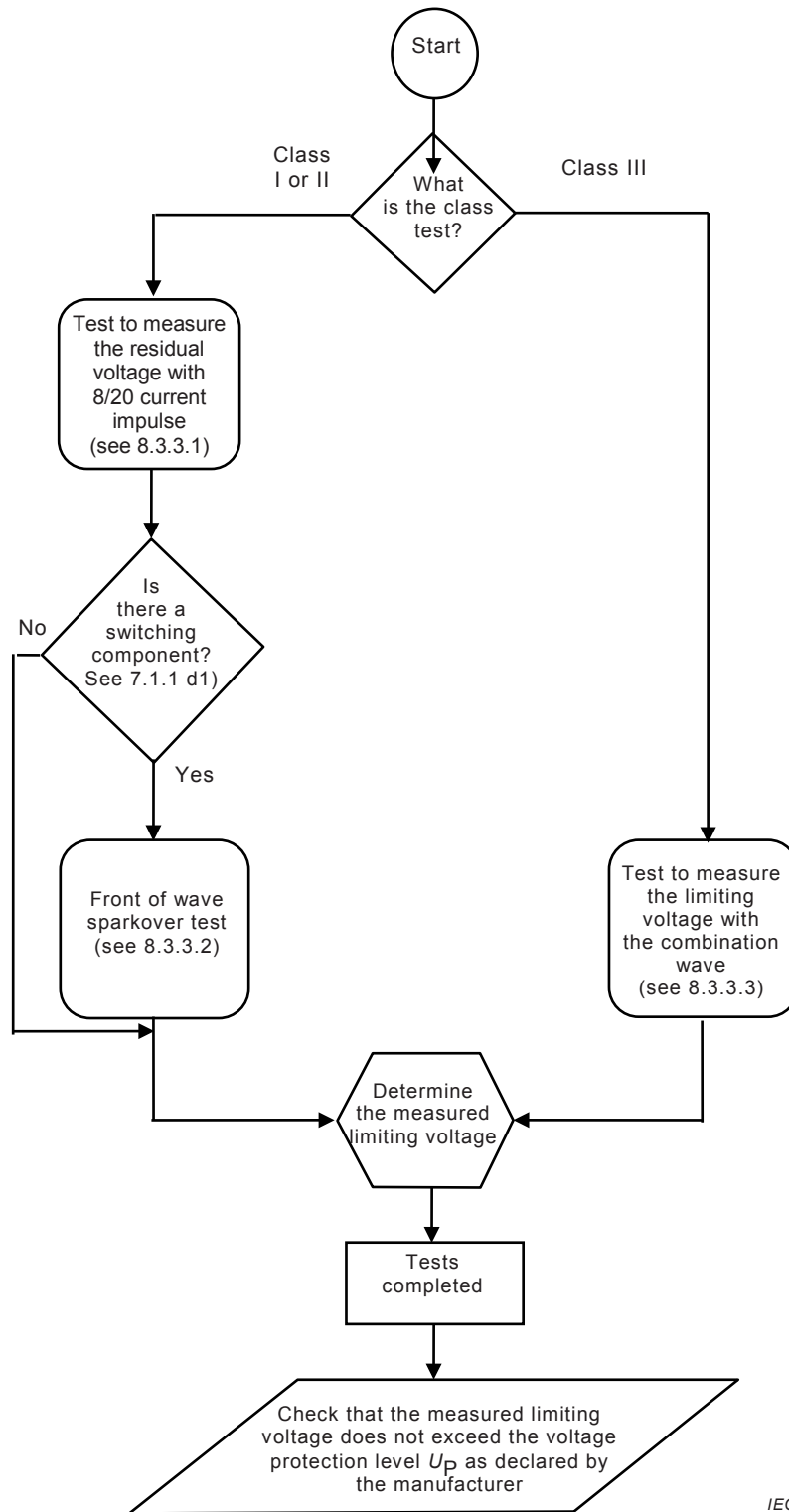

IEC 206/11

Figure 5 – Flow chart of testing to check the voltage protection level  $U_p$

**Table 7 – Tests to be performed to determine the measured limiting voltage**

	Class I	Class II	Class III
Test 8.3.3.1	X	X	
Test 8.3.3.2	X <sup>a</sup>	X <sup>a</sup>	
Test 8.3.3.3			X
<sup>a</sup> To be performed only on voltage switching and combination type SPDs.			

The following specific test conditions apply.

- All one-port SPDs shall be tested unenergized.
- All two-port SPDs shall be tested energized for the tests according 8.3.3.1 and 8.3.3.3 by means of a voltage source having a nominal current of at least 5 A at  $U_C$ . Positive impulses are applied at the  $(90 \pm 5)^\circ$  point and negative impulses at  $(270 \pm 5)^\circ$  point on the sinusoidal voltage waveform.
- For a one-port SPD having terminals, the test is performed without external disconnectors and the voltage is measured at the terminals. For a one-port SPD having connecting leads the voltage is measured with external lead lengths of 150 mm. For a two-port SPD, and a one-port SPD having separate load terminals, the voltage for determining the measured limiting voltage is measured at the output/load port or load terminals of the SPD and the voltage for determining  $U_{max}$  is measured at the input/line port or terminals of the SPD.
- The measured limiting voltage and  $U_{max}$  are determined by the tests performed according to Figure 5 and Table 7, relevant to the SPD test class.

### 8.3.3.1 Residual voltage with 8/20 current impulses

- When testing SPDs to class I, 8/20 current impulses with a sequence of crest values of approximately 0,1; 0,2; 0,5; 1,0 times the crest value of  $I_{imp}$  shall be applied. When testing SPDs to class II, 8/20 current impulses with a sequence of crest values of approximately 0,1; 0,2; 0,5; 1,0 times  $I_n$  shall be applied. If the SPD contains only voltage-limiting components, this test needs only to be performed at crest values of  $I_{imp}$  for test class I or  $I_n$  for test class II. When  $I_{max}$  is declared by the manufacturer an additional 8/20 current impulse with a crest value of  $I_{max}$  shall be applied and the residual voltage shall be measured and recorded.
- One sequence of positive polarity and one sequence of negative polarity are applied to the SPD.
- The interval between individual impulses shall be long enough for the sample to cool down to ambient temperature.
- A current and a voltage oscillogram shall be recorded for each impulse. If relevant, the (absolute) crest values shall be plotted into a discharge current versus residual voltage diagram to  $I_n$  or  $I_{imp}$ . A curve which best fits the data points shall be drawn. There shall be sufficient points on the curve to ensure that there are no significant deviations on the curve up to  $I_n$  or  $I_{imp}$ .
- The residual voltage used for determining the measured limiting voltage is the highest voltage value corresponding to the range of currents for:
  - class I: up to  $I_{imp}$
  - class II: up to  $I_n$

NOTE The residual voltage is the highest crest value measured during surge current flow. Any high frequency disturbances and spikes before and during current flow caused by specific generator design, like crowbar generators, are disregarded.

- The value for determining  $U_{max}$  is the highest residual voltage measured at  $I_n$ ,  $I_{max}$  or  $I_{imp}$ , as applicable depending on the SPD test class.

### 8.3.3.2 Front-of-wave sparkover voltage

The 1,2/50 voltage impulse is used. The generator voltage is set to an open circuit output voltage of 6 kV.

- a) 10 impulses are applied to the SPD, five of positive and five of negative polarity.
- b) The interval between individual impulses shall be long enough for the sample to cool down to ambient temperature.
- c) If sparkover is not observed during each of the 10 impulses on the front of the wave, then a) and b) above are repeated with the generator output voltage increased up to a maximum 10 kV. This shall be recorded in the test report.
- d) The voltage at the SPD shall be recorded with an oscilloscope.
- e) The value for determining the measured limiting voltage and  $U_{\max}$  is the maximum sparkover voltage recorded during this test.

### 8.3.3.3 Limiting voltage with the combination wave

To perform this test a combination wave generator is used.

- a) The interval between the individual impulses shall be long enough for the sample to cool down to ambient temperature.
- b) The voltage of the combination wave generator is set to provide an open-circuit voltage of 0,1; 0,2; 0,5; 1,0 times the  $U_{OC}$  as declared by the manufacturer for the SPD. If the SPD only contains voltage-limiting components this test needs to be carried out at  $U_{OC}$  only.
- c) With these generator settings four surges will be applied to the SPD at each amplitude: two with positive and two with negative polarity.
- d) An oscillographic record shall be made of the current delivered by the generator into the SPD and the voltage at the output port of the SPD for each impulse.
- e) The value for determining the measured limiting voltage and  $U_{\max}$  is the maximum voltage recorded during this test.

NOTE This may either be the sparkover voltage or the residual voltage depending on the SPD design.

### 8.3.3.4 Pass criteria for all measured limiting voltage tests

The pass criteria **B**, **C**, **I** and **M** according to Table 4 shall apply.

### 8.3.4 Operating duty test

An overview is given in the flow chart for the operating duty test in Figure 6.

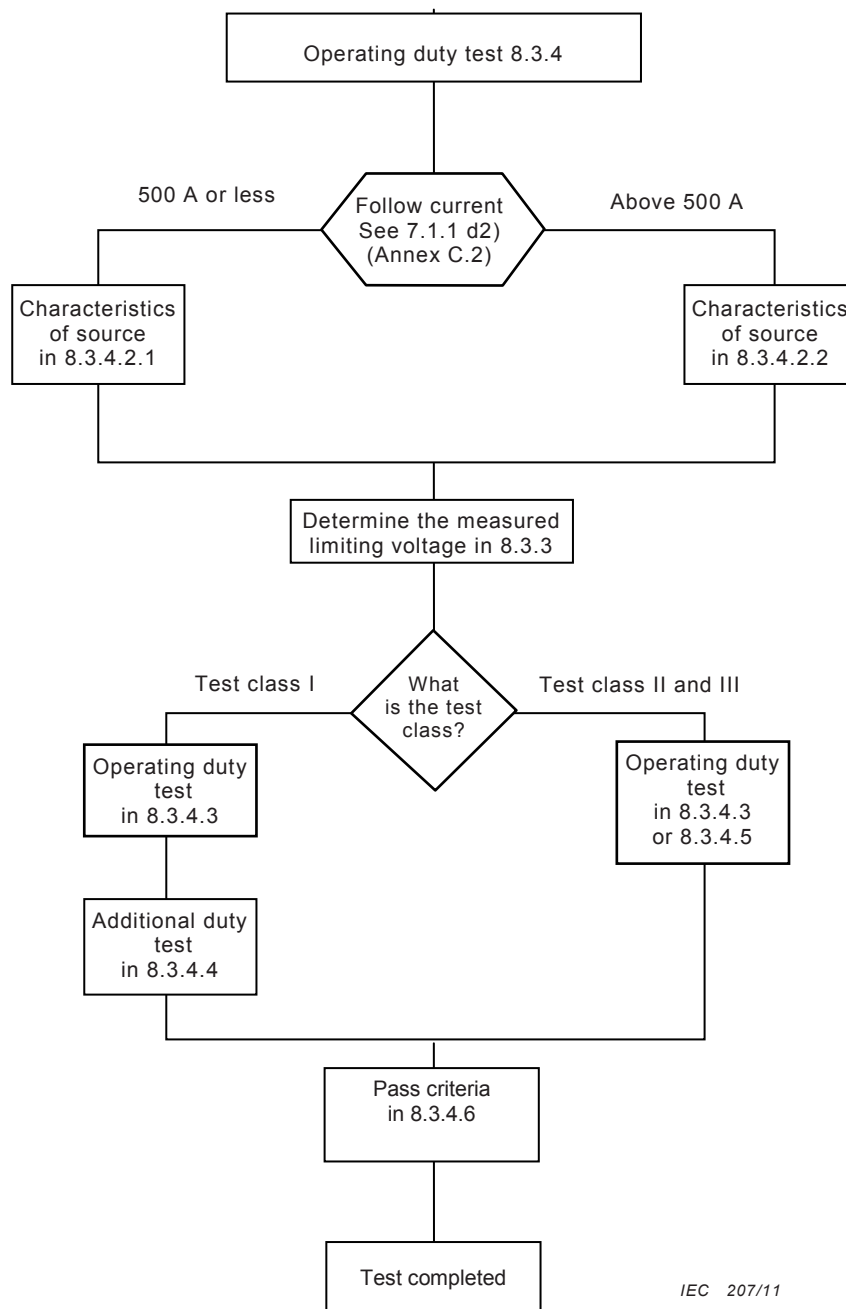

IEC 207/11

Figure 6 – Flow chart of the operating duty test

### 8.3.4.1 General

This is a test in which service conditions are simulated by the application of a stipulated number of specified impulses to the SPD while it is energized at the maximum continuous operating voltage  $U_c$  via an a.c. source according to 8.3.4.2.

The test setup shall comply in with the circuit diagram given in Figure 7.

The measured limiting voltage shall be determined using the tests described in 8.3.3.

To avoid overstress of the samples, the test is performed:

- according to 8.3.3.1, but only at a crest value corresponding to  $I_{imp}$  for test class I
- according to 8.3.3.1, but only at  $I_n$  for test class II

- according to 8.3.3.3, but only at  $U_{oc}$  for test class III

with one positive and one negative surge applied.

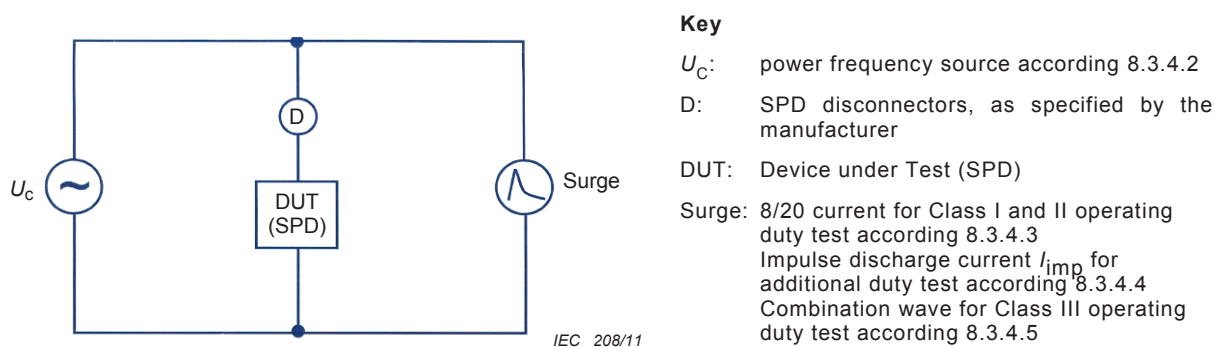

**Figure 7 – Test set-up for operating duty test**

### 8.3.4.2 Power frequency source characteristics for the operating duty test

#### 8.3.4.2.1 SPDs with follow current 500 A or less

The test sample shall be connected to a power frequency voltage source. The impedance of the power source shall be such that during the flow of follow current the crest value of the power frequency voltage, measured at the SPD terminals, does not fall below the crest value of its  $U_C$  by more than 10 %.

#### 8.3.4.2.2 SPDs with follow current above 500 A

The test sample shall be connected to a power frequency voltage at  $U_C$  with a prospective short-circuit current being:

- either equal to the follow current interrupt rating  $I_{fi}$  declared by the manufacturer in accordance with Table 8
- or 500 A

whichever is greater, except for SPDs which are only connected between neutral and protective earth in TT- and/or TN-Systems, for which the prospective short-circuit current shall be at least 100 A.

NOTE For information on SPD follow current interrupt rating coordination with the available prospective short-circuit current of the particular power distribution system at the point of installation, refer to IEC 61643-12 and IEC 60364-5-53, Subclause 534.2.3.5.

### 8.3.4.3 Class I and II operating duty tests

Three groups of five impulses of 8/20 current impulses with positive polarity shall be applied. The test samples are connected to a power source according to 8.3.4.2. Each impulse shall be synchronized to the power frequency. Starting from  $0^\circ$  the synchronization angle shall be increased in steps of  $30^\circ$  with a tolerance of  $\pm 5^\circ$  for each synchronization angle. The tests are described in Figure 8.

The SPD shall be energized at  $U_C$ . The prospective short-circuit current of the power source shall comply with 8.3.4.2 during the application of groups of impulses. After the application of each group of impulses and after the interruption of the last follow current (if any) the SPD shall remain energized without interruption for at least 1 min to check for reignition. After the last group of impulses and the 1 min period the SPD either remains applied or is reapplied within less than 30 s to  $U_C$  for another 15 min to check for stability. For that purpose, the short-circuit capability of the power source (at  $U_C$ ) may be reduced to 5 A.

When testing SPDs to class I, 8/20 current impulses with a crest corresponding to  $I_{imp}$  shall be applied.

When testing SPDs to class II, 8/20 current impulses with  $I_n$  shall be applied.

NOTE If an SPD is classified for test class I and test class II, this test may be performed only once, but with the most severe set of parameters of both test classes, subject to agreement by the manufacturer.

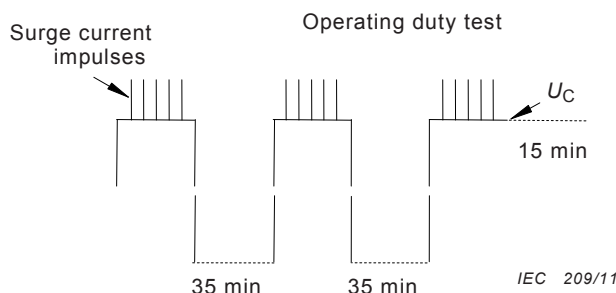

**Figure 8 – Operating duty test timing diagram for test classes I and II**

The interval between the impulses is 50 s – 60 s, the interval between the groups is 30 min – 35 min.

It is not required that the test sample is energized between the groups.

All current impulses shall be recorded and the current records shall show no sign of puncture or flashover of the samples.

#### 8.3.4.4 Additional duty test for test class I

This test is carried out with current impulses in steps up to  $I_{imp}$  passing through the SPD.

The SPD shall be energized at  $U_C$ . The prospective short-circuit current of the power source shall be 5 A during the application of impulses. After the application of each impulse and after interruption of each follow current (if any) the SPD shall remain energized without interruption for at least 1 min to check for re-ignition. After that period the SPD either remains applied or is reapplied within less than 30 s to  $U_C$  for another 15 min to check for stability. For that purpose the short-circuit capability of the power source shall also be 5 A.

Current impulses of positive polarity shall be initiated in the corresponding positive crest value of the power frequency voltage source to the energized test sample as follows.

- One current impulse at 0,1  $I_{imp}$ ; check thermal stability; cool down to ambient temperature.
- One current impulse at 0,25  $I_{imp}$ ; check thermal stability; cool down to ambient temperature.
- One current impulse at 0,5  $I_{imp}$ ; check thermal stability; cool down to ambient temperature.
- One current impulse at 0,75  $I_{imp}$ ; check thermal stability; cool down to ambient temperature.
- One current impulse at 1,0  $I_{imp}$ ; check thermal stability; cool down to ambient temperature.

The timing diagram is described in Figure 9

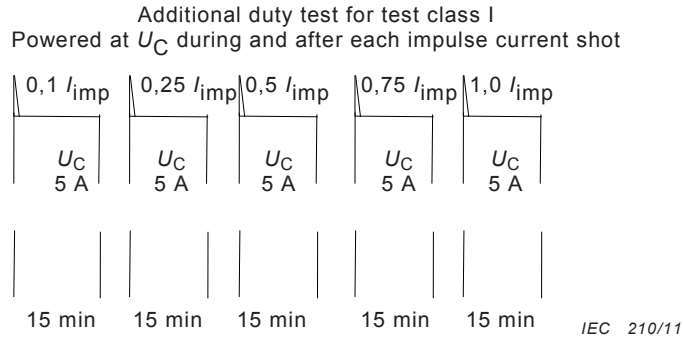

**Figure 9 – Additional duty test timing diagram for test class I**

### 8.3.4.5 Class III operating duty tests

The SPD is tested with three groups of impulses corresponding to  $U_{oc}$  with:

- five positive impulses initiated at crest value of positive half cycle ( $\pm 5^\circ$ )
- five negative impulses initiated at crest value of negative half cycle ( $\pm 5^\circ$ )
- five positive impulses initiated at crest value of positive half cycle ( $\pm 5^\circ$ )”

The timing diagram is described in Figure 10.

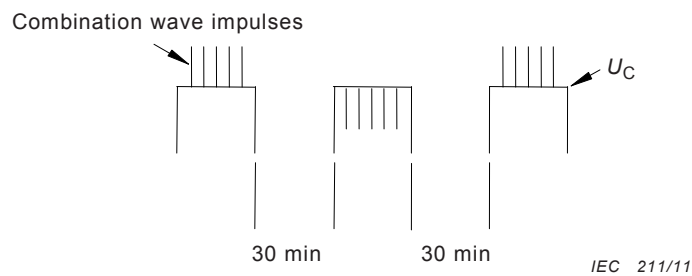

**Figure 10 – Operating duty test timing diagram for test class III**

### 8.3.4.6 Pass criteria for all operating duty tests and for the additional duty test for test class I

The pass criteria **A**, **B**, **C**, **D**, **E**, **F**, **G** and **M** according to Table 4 shall apply.

## 8.3.5 Disconnectors and safety performance of overstressed SPDs

### 8.3.5.1 Temperature withstand test

The SPD is kept in a heated cabinet at an ambient temperature of  $80^\circ\text{C} \pm 5\text{K}$  for 24 h.

The pass criteria **C** and **G** according to Table 4 shall apply.

### 8.3.5.2 Thermal stability

#### Test settings

This test procedure addresses two different designs:

- for SPDs containing only voltage limiting components the following procedure a) applies.

- for SPDs containing both voltage limiting and voltage switching components the following procedure b) applies.

### Sample preparation

For SPDs with different non-linear components connected in parallel, this test has to be performed for every current path of the SPD by disconnecting/interrupting all the remaining current paths. If components of the same type and parameters are connected in parallel, they shall be tested as one current path.

Any voltage switching component within the current path under test, which is connected in series with a voltage limiting component shall be short-circuited by a copper wire or dummy with a diameter such that it does not melt during the test.

The manufacturer shall provide samples prepared according to the above requirements.

#### a) Test procedure for SPDs having only voltage limiting components

The test samples shall be connected to a power frequency source.

The voltage shall be high enough to allow a current to flow through the SPD. For this test, the current is set to a constant value. The tolerance for the test current is  $\pm 10\%$ . The test is started at a value of 2 mA r.m.s. for the first sample, or at  $U_C$ , if the leakage current at  $U_C$  does already exceed 2 mA r.m.s.

This value of current is then increased in steps of either 2 mA or 5 % of the previously adjusted test current, whichever is greater.

For the other two samples the starting point shall be changed from 2 mA to a current corresponding to 5 steps below the current value at which the first sample disconnected.

Each step is maintained until thermal equilibrium is reached (i.e. variation of temperature at the hottest spot less than 2 K within 10 min).

The outer surface temperature on the hottest spot of the housing of the SPD (for accessible SPDs only) and the current through the SPD are monitored continuously.

NOTE 1 The hottest spot of the SPD may be determined by an initial test or alternatively many points may be monitored in order to determine the hottest spot.

This test is interrupted if all non-linear components under test are disconnected. The voltage shall not be increased further in order to avoid any malfunction of disconnectors.

NOTE 2 In case of doubt that all non-linear components are disconnected a visual inspection should be performed.

NOTE 3 Cracking of components alone is not considered as disconnection.

If the voltage across the SPD falls below  $U_{REF}$  during the test, the current regulation is discontinued and the voltage is adjusted back to  $U_{REF}$  and maintained for a duration of 15 min. Continuous current monitoring is not longer required. The source shall have a short-circuit current capability which will not limit the current before any disconnector operates. The maximum available current value shall not exceed the short-circuit current rating declared by the manufacturer.

#### b) Test procedure for SPDs having a voltage switching component in series with other components

The SPD is energized with a power frequency source at  $U_{REF}$  and having a short-circuit current capability which will not limit the current before any disconnector operates. The

maximum available current value shall not exceed the short-circuit current rating declared by the manufacturer.

If no significant current flows, test procedure a) shall be followed.

NOTE 4 The usage of “no significant current” infers that the SPD has not entered its onset of conduction transition (i.e. SPD remains thermally stable).

### Pass criteria

The pass criteria **C, H, I, J, M** and **O** according to Table 4 shall apply.

In addition for indoor SPDs the surface temperature rise shall not exceed 120 K during and after the test. Five (5) min after disconnection of all non-linear components under test the surface temperature rise shall not exceed 80 K.

#### 8.3.5.3 Short-circuit current behaviour tests

This test is not applied to SPDs which are either

- classified for outdoor use and for mounting out of reach, or
- for connection N-PE in TN and/or TT systems only.

**Table 8 – Prospective short-circuit current and power factor**

$I_p$ (kA) $\begin{matrix} +5 \\ 0 \end{matrix}$ %	$\cos \varphi$ $\begin{matrix} 0 \\ -0,05 \end{matrix}$
$I_p \leq 1,5$	0,95
$1,5 < I_p \leq 3,0$	0,9
$3,0 < I_p \leq 4,5$	0,8
$4,5 < I_p \leq 6,0$	0,7
$6,0 < I_p \leq 10,0$	0,5
$10,0 < I_p \leq 20,0$	0,3
$20,0 < I_p \leq 50,0$	0,25
$50,0 < I_p$	0,2
NOTE Recovery voltage according to IEC 60947-1.	

The test sample shall be mounted in accordance with the manufacturer's published recommendations and connected with conductors of the maximum cross section according to 8.4.2, keeping the cables connecting the sample to a maximum length of 0,5 m each.

### Sample preparation

For SPDs with non-linear components connected in parallel, separate sets of three samples shall be prepared in the manner described below for every current path of the SPD which contains one or more non-linear component described in 3.1.4 and 3.1.5.

Current paths containing voltage switching components with combined disconnecter function, having an impulse withstand voltage equal or greater than 6kV and a dielectric withstand equal or greater than 2500 V/50 Hz for 1 min in normal operating condition, are tested without any preparation and only in conjunction with other current paths prepared in the manner described below.

Voltage limiting components and voltage switching components described in 3.1.4 and 3.1.5 shall be replaced by appropriate copper blocks (dummies) ensuring that the internal connections and their cross-section and surrounding material (e.g. resins) and packaging are not changed.

Samples according to the above requirement shall be provided by the manufacturer.

### Test procedure

This test shall be performed at two different test settings with a separate set of prepared test samples for each setting a) and b):

#### a) Test at the declared short-circuit current rating

The sample is connected to a power frequency source at  $U_{REF}$ . The prospective short-circuit current as declared by the manufacturer and with the corresponding power factor as given in Table 8 are adjusted at the SPD terminals.

The test is carried out twice with  $U_{REF}$  applied at  $(45 \pm 5)$  electrical degrees and at  $(90 \pm 5)$  electrical degrees after the zero crossing of the voltage.

If a replaceable or resettable internal or external disconnecter operates, the relevant disconnecter shall be replaced or reset each time. If the disconnecter cannot be replaced or reset, the test is stopped.

#### Pass criteria

The pass criteria **C**, **H**, **I**, **J**, **K**, **M** and **N** according to Table 4 shall apply.

#### b) Test at low short-circuit current

A power frequency source at  $U_{REF}$ , having a prospective short-circuit current of five times the rated current of the maximum overcurrent protection (if declared by the manufacturer), and a power factor according to Table 8, shall be applied for  $5 \text{ s} \pm 0,5 \text{ s}$ . If no external overcurrent protection is required by the manufacturer, a prospective short-circuit current of 300 A is used.

The test is carried out once with  $U_{REF}$  applied at  $(45 \pm 5)$  electrical degrees after the zero crossing of the voltage.

#### Pass criteria

The pass criteria **C**, **I**, **M** and **N** according to Table 4 shall apply.

If disconnection occurs during this test, pass criteria **H**, **J**, and **K** according to Table 4 shall apply in addition.

#### 8.3.5.3.1 Additional test for SPDs with $I_{fi}$ lower than the declared short-circuit current rating ( $I_{SCCR}$ )

The test procedure according to 8.3.5.3 a) is repeated but without following the sample preparation according 8.3.5.3.

The voltage switching component(s) of the SPD is triggered with a positive surge current (8/20 or other appropriate waveshape) at  $(35 \pm 5)$  electrical degrees after the zero crossing of the voltage on the positive half wave. The surge current shall be high enough to initiate a follow current but shall in no case exceed  $I_n$ .

To ensure that no external disconnecter operates due to the trigger surge, all external disconnectors shall be placed in series with the power frequency source as shown in Figure 11.

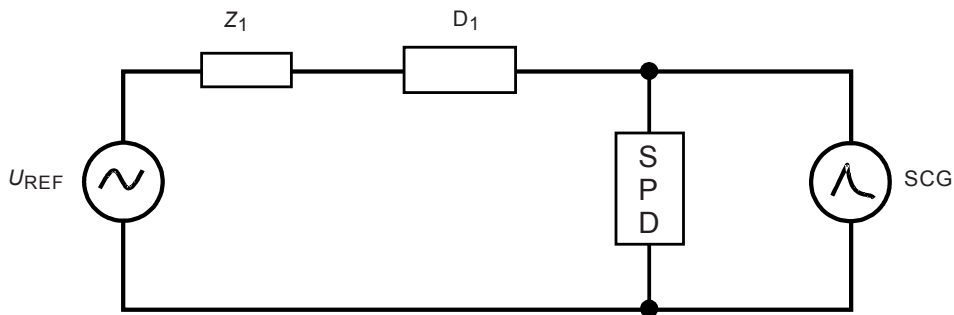

IEC 212/11

**Key**

- $Z_1$  Impedance to adjust the prospective short-circuit current, according to Table 8
- $D_1$  External disconnector
- SCG Surge current generator with coupling device

**Figure 11 – Test circuit for SPD with  $I_{fi}$  lower than the declared short-circuit rating**

**Pass criteria**

The pass criteria **C, H, I, J, K, M** and **N** according to Table 4 shall apply.

**8.3.5.3.2 Additional test for SPD's failure mode simulation**

**Sample preparation**

For this test any electronic indicator circuitry may be disconnected.

New samples shall be used and fitted as in normal use, according to the manufacturer's instructions and connected with conductors of the maximum cross section according to 8.4.2. The maximum length of the cables connecting the sample shall be of 0,5 m each.

External disconnectors, if recommended by the manufacturer, shall be used.

**Test procedure**

The test sample shall be connected to a power frequency voltage source at the following conditioning voltages:

- for SPDs rated  $U_C$  up to 440 V, apply a voltage equal to  $1\,200\ V_{rms} \begin{smallmatrix} +5 \\ 0 \end{smallmatrix} \%$ ,
- for SPDs with  $U_C$  rated above 440 V, apply a voltage equal to 3 times  $U_C \begin{smallmatrix} +5 \\ 0 \end{smallmatrix} \%$ .

The conditioning voltage is applied for a duration of  $5\ s \begin{smallmatrix} +5 \\ 0 \end{smallmatrix} \%$ . The prospective short-circuit current of this power source for conditioning shall be adjusted to a value between 1A and  $20\ A_{rms} \begin{smallmatrix} +5 \\ 0 \end{smallmatrix} \%$ , as provided by the manufacturer according to 7.1.1 d5).

Following the application of the conditioning voltage a voltage equal to  $U_{REF} \begin{smallmatrix} 0 \\ -5 \end{smallmatrix} \%$  with a short-circuit current capability as given below, shall be applied to the sample for a period of 5 min  $\begin{smallmatrix} +5 \\ 0 \end{smallmatrix} \%$  or for at least 0,5s after interruption of the current by an internal or external disconnector.

The transition from conditioning voltage application to  $U_{REF}$  application shall be performed without interruption. The current flow through the SPD shall be monitored. An appropriate test circuit and timing diagram is shown in Figure 12 and Figure 13.

The prospective short-circuit current of the power source at  $U_{REF}$  shall have a tolerance of  ${}^{+5}_0$  % at the location where the SPD is connected. The power factor of the power source shall comply with Table 8.

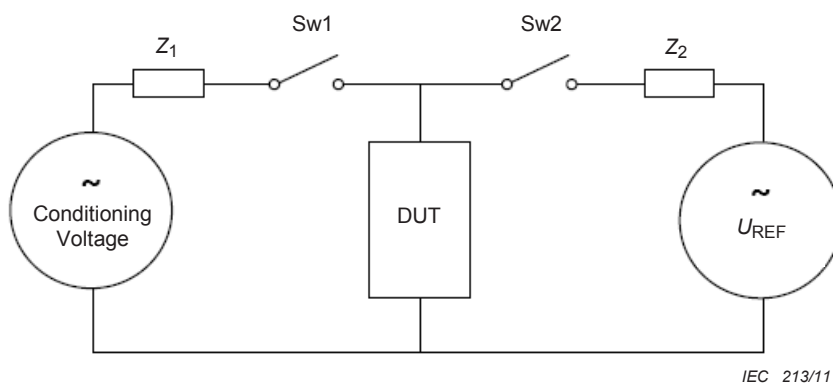

IEC 213/11

**Key**

- Z<sub>1</sub>: Impedance to adjust the prospective short-circuit current of preconditioning generator
- Z<sub>2</sub>: Impedance to adjust the prospective short-circuit current of  $U_{REF}$
- Sw1: Mechanical or static switch to apply the preconditioning stress to the SPD
- Sw2: Mechanical or static switch to apply the reference test voltage to the preconditioned DUT
- Sw1 and Sw2 can be mechanical or static
- DUT: Device under test (SPD + Disconnecter, if applicable)

**Figure 12 – Test circuit for SPD's failure mode simulation**

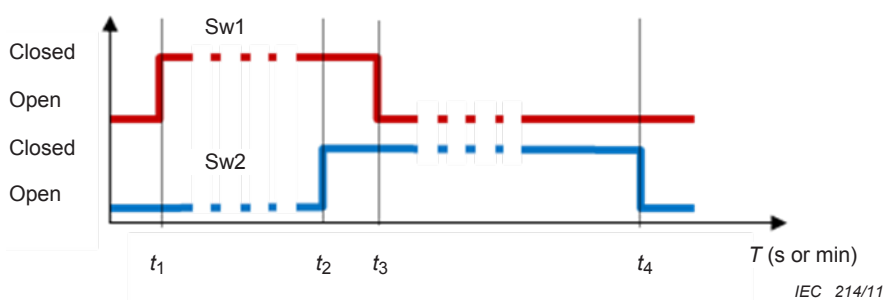

IEC 214/11

**Key**

- $t_1 = 0$
- $t_3 \geq t_2 \geq 5\text{ s } -0\%$
- $t_2 \leq t_3 < 5\text{ s } +5\%$
- $t_4 = 5\text{ min } {}^{+5}_0$  % or.  $\geq 0,5\text{ s}$  after current interruption

**Figure 13 – Timing diagram for SPD's failure mode simulation**

Each of the following tests shall be performed on a new set of three preconditioned samples as above at  $U_{REF}$  with a short-circuit current of 100 A, 500 A and 1 000 A, respectively, unless these values exceed the declared short-circuit rating of the SPD.

A further test shall be performed on three preconditioned samples as above and at  $U_{REF}$  with a prospective short-circuit current equal to the manufacturer's declared short-circuit current rating. For this test, the time interval between the completion of the conditioning test and the application of  $U_{REF}$  shall be as short as possible and shall not exceed 100 ms.

If all oscillograms of the tests on the first set of samples (100 A test set up) show a disconnection within 5 s during the application of the conditioning voltage, no further test is performed.

### Pass criteria

The pass criteria **C**, **I**, **M** and **N** according to Table 4 shall apply. In general pass criteria **H** and **J** according to Table 4 shall apply in addition, except for

- short circuiting type SPDs
- SPDs where the current is interrupted during the application of  $U_{REF}$

where no disconnection occurs.

For this test any damage to electronic indicator circuitry during the conditioning test is not regarded as a failure.

### 8.3.6 Insulation resistance

This test is not applicable to SPDs having a metallic enclosure connected to protective earth.

#### Sample preparation

Additional entry holes for cables, if there are any, are left open. If there are any knockouts, one of them is opened. Coverings and other parts which are detachable without tools, are removed and undergo the same moisture treatment.

#### Test procedure

The moisture treatment is carried out in a humidity cabinet at a relative humidity of 93 %  $\pm$ 3 % RH. The air temperature is kept at all points, where the test sample can be positioned, within  $\pm$ 2 K at a suitable temperature  $T$  between 20 °C and 30 °C. Before putting the test samples into the humidity cabinet, they shall have a temperature between  $T$  and  $(T+4)$  in °C.

NOTE 1 In most cases the test samples can be brought to the required temperature, if they are kept at least 4 h at this temperature before the moisture treatment.

The test samples shall be kept in the humidity cabinet for 2 days (48 h).

NOTE 2 The required humidity can be achieved by putting in the humidity cabinet, a saturated hydrous solution of sodium sulphate ( $\text{Na}_2\text{SO}_4$ ) or potassium nitrate ( $\text{KNO}_3$ ), having a sufficient contact surface with the air.

After a delay of between 30 min and 60 min following the humidity treatment, the insulation resistance is measured 60 s after having applied a d.c. voltage of 500 V.

This measurement is carried out in the humidity cabinet or in the room into which the specimens were brought to reach the determined temperature, after having refitted the parts which might have been detached.

The measurement has to be performed as follows:

- a) between all interconnected live parts and the SPDs body accessible to accidental contact

The expression "body" in the sense of this test means

- all touchable metal parts and a metal foil on surfaces of insulating material, which are touchable after installation as for normal use,
- the surface on which the SPD is mounted, if necessary, covered with metal foil,
- screws and other facilities for fastening the SPD on its support.

For these measurements, the metal foil is put on in such a way, that perhaps existing casting mass is effectively tested.

Protective components connected to PE may be disconnected for this test.

- b) between the live parts of the SPD main circuit and live parts of separate isolated circuits, if there are any.

### Pass criteria

The insulation resistance shall not be lower than

- 5 MΩ for the measurements according to a),
- 2 MΩ for the measurements according to b).

### 8.3.7 Dielectric withstand

SPDs classified for outdoor use are tested between the terminals with the internal parts removed. During this test, the SPD is subjected to sprinkling according to 9.1 of IEC 60060-1.

SPDs classified for indoor are tested as indicated in a) and b) of 8.3.6.

SPDs are tested with an a.c. voltage according to Table 9. Starting with not more than half the required a.c. voltage, this voltage is increased to the full value within 30 s which is maintained for 1 min.

**Table 9 – Dielectric withstand**

SPD continuous operating voltage V	AC test voltage kV
$U_c \leq 100$	1,1
$100 < U_c \leq 200$	1,7
$200 < U_c \leq 450$	2,2
$450 < U_c \leq 600$	3,3
$600 < U_c \leq 1\ 200$	4,2
$1\ 200 < U_c \leq 1\ 500$	5,8

### Pass criteria

Arcing or puncturing shall not occur, however, partial discharges are accepted if the voltage change during the discharge is less than 5 %.

The power transformer used for testing shall be designed in such a way that after having been adjusted to the test voltage at its open terminals it will generate a short-circuit current of at least 200 mA after short-circuiting the terminals. An overcurrent relay, if any, shall only react if the test circuit current exceeds 100 mA. The device for measuring the test voltage shall have a precision of  $\pm 3$  %.

### 8.3.8 Behaviour under temporary overvoltages (TOVs)

#### 8.3.8.1 TOVs caused by faults in the low voltage system

The SPDs shall be tested using either the TOV voltages  $U_T$  given in the relevant tables of Annex B, or the TOV-voltages stated by the manufacturer according to 7.1.1 c1), whichever values are higher.

Table B.1 shall be applied to all SPDs and, depending on the information given by the manufacturer on 7.1.1 c1), the additional tables according to Clause B.1 of Annex B shall also be applied.

#### Test procedure

New samples shall be used and fitted as in normal use, according to the manufacturer's instructions.

The test sample shall be connected to a power frequency voltage of  $U_T \begin{smallmatrix} 0 \\ -5 \end{smallmatrix}$  % for a duration

$t_T \begin{smallmatrix} +5 \\ 0 \end{smallmatrix}$  %.

Except for loss of neutral tests, this power source for  $U_T$ , shall be capable of delivering a current high enough to ensure that the voltage at the SPD terminals does not fall below  $U_T$  by more than 5 % during the test. For loss of neutral tests this voltage source shall be capable of delivering a prospective short-circuit current of 10 A.

Immediately following the application of  $U_T$ , a voltage equal to  $U_{REF} \begin{smallmatrix} 0 \\ -5 \end{smallmatrix}$  % with the same current capability, shall be applied to the test sample for a period of 15 min  $\begin{smallmatrix} +5 \\ 0 \end{smallmatrix}$  %.

For loss of neutral tests, this power source for  $U_{REF}$  shall be capable of delivering a prospective short-circuit current equal to the declared short-circuit current rating of the SPD.

The time interval between the test periods shall be as short as possible and shall in any case not exceed 100 ms. An example of a test circuit and a corresponding timing diagram to perform this test is given in Figure 14 and Figure 15.

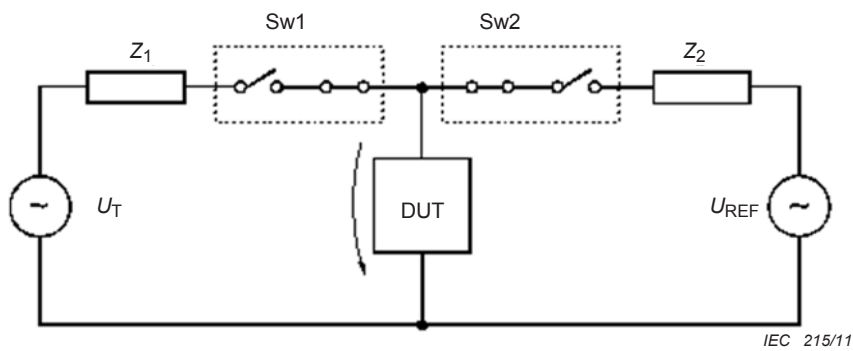

**Key**

- $U_T$  Temporary overvoltage according Annex B
- $U_{REF}$  Reference test voltage according Annex A
- $Z_1$  Impedance to adjust the prospective short circuit current of  $U_T$
- $Z_2$  Impedance to adjust the prospective short circuit current of  $U_{REF}$
- Sw1 Switch to apply the temporary overvoltage to the SPD
- Sw2 Switch to apply the reference test voltage to the SPD
- DUT: Device under test (SPD + Disconnecter, if applicable)

**Figure 14 – Example of a test circuit to perform the test under TOVs caused by faults in the low voltage system**

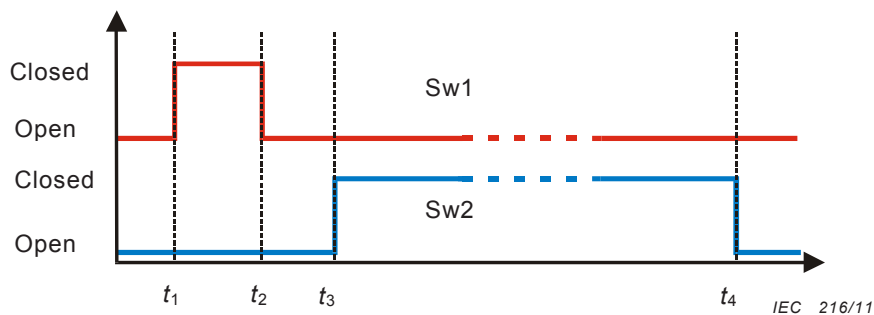

**Key**

- $t_1 = 0$
- $t_2 = t_T^{+5}_0 \%$
- $t_2 \leq t_3 < (t_2 + 100 \text{ ms})^{+5}_0 \%$
- $t_4 = t_T + 15 \text{ min }^{+5}_0 \%$

**Figure 15 – Timing diagram for the test under TOVs caused by faults in the low voltage system**

**Pass criteria**

a) TOV failure mode:

The pass criteria **C**, **H**, **I**, **J**, **K**, **L** and **M** according to Table 4 shall apply.

b) TOV withstand mode:

The pass criteria **A, B, C, D, E, F, G, I, L** and **M** according to Table 4 shall apply.

### 8.3.8.2 TOVs caused by faults in the high (medium) voltage system

SPDs connected to PE and for use on power distribution systems shall be tested using either the TOV voltages  $U_T$  given in Annex B, or the TOV voltages stated by the manufacturer according to 7.1.1 c1), whichever values are higher.

Table B.1 shall be applied to all SPDs and, depending on the information given by the manufacturer on 7.1.1 c1), the additional tables according to clause B.1 of Annex B shall also be applied.

New samples shall be used and fitted as in normal use, according to the manufacturer's instructions, and connected to a test circuit according to Figure 16 or equivalent.

#### Test procedure

The test voltage  $U_T \begin{smallmatrix} 0 \\ -5 \end{smallmatrix}$  % is applied to the test sample at 90 electrical degrees of phase L1 by closing switch S1.

After the TOV application time  $t_T \begin{smallmatrix} 0 \\ -5 \end{smallmatrix}$  % switch S2 is closed automatically.

This connects the SPD's PE-terminal to the neutral (via the current limiting resistor R2) by short-circuiting the TOV-transformer's (T2) secondary winding. This results in the operation of fuse F2 protecting the TOV transformer.

An example of a test circuit and a corresponding timing diagram to perform this test is given in Figure 16 and Figure 17.

Additional examples of alternative test circuits are given in Annex E.

Other test circuits are permitted as long as they ensure the same stress to the SPD.

The prospective short-circuit current of the power source for  $U_{REF}$  shall be equal to five times the rated current of the maximum overcurrent protection declared by the manufacturer, or 300 A if no maximum overcurrent protection is declared. The tolerance for the current is  $\begin{smallmatrix} +10 \\ 0 \end{smallmatrix}$  %.

The prospective short-circuit current delivered by the TOV transformer shall be adjusted to

300 A  $\begin{smallmatrix} +10 \\ 0 \end{smallmatrix}$  % by R2.

With the exception of SPDs connected neutral to ground,  $U_{REF}$  remains applied to the test sample for 15 min without interruption until switch S1 is reopened.

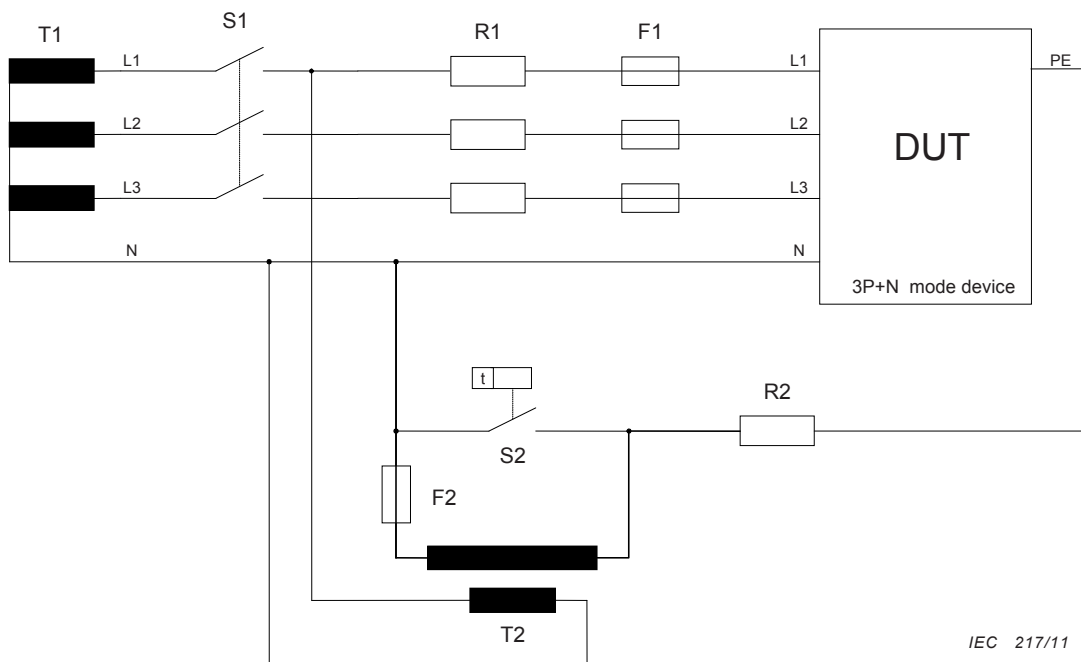

**Key**

- S1 Main switch
- S2 Timer switch – closing 200 ms after main switch
- F1 Maximum recommended overcurrent protection according to manufacturer's instructions
- F2 TOV transformer protection fuse (needs to withstand 300 A for 200 ms)
- T1 Power supply transformer with a secondary voltage at  $U_{REF}$
- T2 TOV transformer with primary voltage at  $U_{REF}$  and secondary voltage of 1 200 V
- R1 Current-limiting resistor to adjust the prospective short-circuit current of the power supply at  $U_{REF}$
- R2 Current-limiting resistor to adjust the prospective short-circuit current of the TOV circuit to 300 A (approximately 4  $\Omega$ )
- DUT Device under test

**Figure 16 – Example of circuit for testing SPDs for use in TT systems under TOVs caused by faults in high (medium) voltage systems**

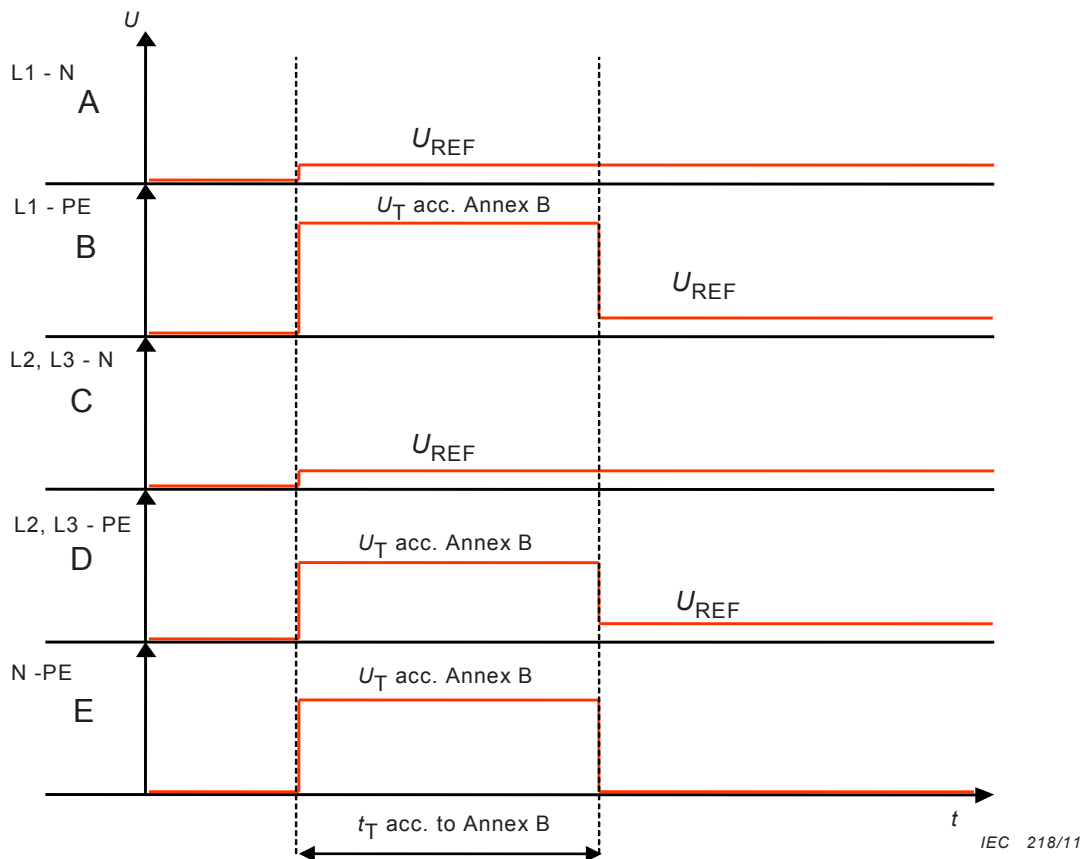

**Figure 17 – Timing diagram for use in testing SPDs under TOVs caused by faults in the high (medium) voltage system using circuit of Figure 16**

**Pass criteria:**

a) TOV failure mode:

The pass criteria **C, H, I, J, K, L** and **M** according to Table 4 shall apply.

b) TOV withstand mode:

The pass criteria **A, B, C, D, E, G, I, K, L** and **M** according to Table 4 shall apply.

**8.4 Mechanical tests**

**8.4.1 Reliability of screws, current-carrying parts and connections**

Compliance is checked by inspection and for screws which are operated when connecting up the SPD by the following test.

The screws are tightened and loosened:

- ten times for screws in engagement with a thread of insulating material,
- five times in all other cases.

Screws or nuts in engagement with a thread of insulating material are completely removed and reinserted each time unless the construction of the screw prevents this.

The test is made by means of a suitable test screwdriver or spanner applying a torque as shown in Table 10 or according to the manufacturer’s specification, whichever is greater.

The screws shall not be tightened in jerks.

The conductor is moved each time the screw is loosened.

**Table 10 – Screw thread diameters and applied torques**

Nominal diameter of thread mm	Torque Nm		
	I	II	III
Up to and including 2,8	0,2	0,4	0,4
Over 2,8 up to and including 3,0	0,25	0,5	0,5
Over 3,0 up to and including 3,2	0,3	0,6	0,6
Over 3,2 up to and including 3,6	0,4	0,8	0,8
Over 3,6 up to and including 4,1	0,7	1,2	1,2
Over 4,1 up to and including 4,7	0,8	1,8	1,8
Over 4,7 up to and including 5,3	0,8	2,0	2,0
Over 5,3 up to and including 6,0	1,2	2,5	3,0
Over 6,0 up to and including 8,0	2,5	3,5	6,0
Over 8,0 up to and including 10,0	–	4,0	10,0

Column I applies to screws without heads, if the screw, when tightened, does not protrude from the hole; it also applies to other screws which cannot be tightened by means of a screwdriver with a blade wider than the diameter of the screw.

Column II applies to other screws which are tightened by means of a screwdriver.

Column III applies to screws and nuts which are tightened by means other than a screwdriver.

Where a screw has a hexagonal head with a slot for tightening with a screwdriver and the values in columns II and III are different, the test is made twice, applying the torque specified in column III to the hexagonal head and, on another sample, applying the torque specified in column II by means of a screwdriver. If the values in columns II and III are the same, only the test with the screwdriver is made.

#### Pass criteria

During the test, the screwed connections shall not work loose and there shall be no damage, such as breakage of screws or damage to the head slots, threads, washers or stirrups, that will impair the further use of the SPD.

Enclosures and covers shall not be damaged. This shall be verified by visual inspection.

#### 8.4.2 Terminals for external conductors

The SPD is mounted according to the manufacturer's recommendation on a dull, black-painted wood board of about 20 mm thickness, and protected against undue external heating or cooling.

Unless otherwise specified, the SPD terminals shall be wired with conductors according to:

- Table 11, for two-port devices and one-port devices with separate input/output terminals or,
- the manufacturer's instruction, for other one-port devices.

SPDs tested according to class I and one-port SPDs with a nominal discharge current  $\geq 5$  kA tested according to class II shall be capable of clamping conductors with a cross-section of at least 4 mm<sup>2</sup>.

### 8.4.2.1 Terminals with screws

#### 8.4.2.1.1 General

These tests are made by means of a suitable screwdriver or spanner applying a torque as shown in Table 10.

The terminals are fitted with copper conductors of the smallest or largest cross-sectional areas specified in 8.4.2, solid or stranded, whichever is least favourable.

The conductor is inserted into the terminal for the minimum distance prescribed or, where no distance is prescribed, until it just projects from the far side, and in the position most likely to assist the wire to escape.

The clamping screws are then tightened with a torque equal to two-thirds of that shown in the appropriate column of Table 10.

Each conductor is then subjected to a pull of the value, in newtons, shown in Table 12. The pull is applied without jerks, for 1 min, in the direction of the axes of the conductor space.

During this test, the conductor shall not move noticeably in the terminal.

**Table 11 – Cross-sections of copper conductors for screw-type or screwless terminals**

Maximum continuous load current for two-port SPDs or one-port SPDs with separate input/output terminals <sup>a</sup>	Range of nominal cross-sections to be clamped (single conductor)	
	mm <sup>2</sup>	American Wire Gauge
Up to and including 13	1 to 2,5	18 to 14
Above 13 up to and including 16	1 to 4	18 to 12
Above 16 up to and including 25	1,5 to 6	16 to 10
Above 25 up to and including 32	2,5 to 10	14 to 8
Above 32 up to and including 50	4 to 16	12 to 6
Above 50 up to and including 80	10 to 25	8 to 3
Above 80 up to and including 100	16 to 35	6 to 2
Above 100 up to and including 125	25 to 50	4 to 1

<sup>a</sup> It is required that, for current ratings up to and including 50 A, terminals be designed to clamp solid conductors as well as rigid stranded conductors; the use of flexible conductors is permitted.

Nevertheless, it is permitted that terminals for conductors having cross-sections from 1 mm<sup>2</sup> up to 6 mm<sup>2</sup> be designed to clamp solid conductors only.

#### 8.4.2.1.2 Pull-test for screw terminals

**Table 12 – Pulling forces (screw terminals)**

Cross-section of conductor accepted by the terminal mm <sup>2</sup>	Up to 4	Up to 6	Up to 10	Up to 16	Up to 50
Pull N	50	60	80	90	100

- a) The terminals are fitted with copper conductors (solid or stranded), of the smallest or largest cross-sectional areas as specified in 8.4.2, (whichever is the least favourable) and the terminal screws are tightened with a torque equal to two-thirds of the values shown in the appropriate column of Table 10. The terminal screws are then loosened and the part of the conductor which may have been affected by the terminal is inspected.

##### Pass criteria

The conductors shall show neither undue damage nor severed wires.

Conductors are considered to be unduly damaged if they show deep or sharp indentations.

During the test, terminals shall not work loose and there shall be no damage such as breakage of screws or damage to the head slots, threads, washers or stirrups, that will impair the further use of the terminal.

- b) The terminals are fitted with a rigid stranded copper conductor according to Table 13.

Before insertion in the terminal, the wires of the conductors are suitably reshaped.

The conductor is inserted into the terminal until the conductor reaches the bottom of the terminal or just projects from the far side of the terminal and in the position most likely to assist a wire to escape. The clamping screw or nut is then tightened with a torque equal to two-thirds of that shown in the appropriate column of Table 10.

##### Pass criteria

After the test, no wire of the conductor shall have slipped out of the SPD terminal.

**Table 13 – Conductor dimensions**

Range of nominal cross-sections to be clamped mm <sup>2</sup>	Stranded conductor
	Number of wires
1 to 2,5 <sup>a</sup>	7
1 to 4 <sup>a</sup>	7
1,5 to 6 <sup>a</sup>	7
2,5 to 10	7
4 to 16	7
10 to 25	7
16 to 35	19
25 to 50	Under consideration

<sup>a</sup> If the terminal is intended to clamp solid conductors only (see table footnote of Table 11), the test is not performed.

### 8.4.2.2 Screwless terminals

Compliance is checked by the following tests.

The terminals are fitted with new copper conductors (solid or stranded), of the smallest or largest cross-sectional areas as specified in 8.4.2, (whichever is the least favourable).

Each conductor is then subjected to a pull of the value shown in Table 14. The pull is applied without jerks for 1 min in the direction of the axis of the conductor.

#### Pass criteria

During the test, there shall be no movement of the conductor in the terminal or any indication of damage.

**Table 14 – Pulling forces (screwless terminals)**

<b>Cross-sectional area</b> mm <sup>2</sup>	0,5	0,75	1,0	1,25 1,5	2,0 2,5	3,5 4	5,5 6	8,0 10	14 16	22 25	35 38
<b>Pull force</b> N	30	30	35	40	50	60	80	90	100	135	190

### 8.4.2.3 Insulation piercing connections

#### 8.4.2.3.1 Pull test on terminals designed for single core conductors

Compliance is checked by the following tests.

The terminals are fitted with new copper conductors (solid or stranded), of the smallest or largest cross-sectional areas as specified in 8.4.2, (whichever is the least favourable). Screws, if any, are tightened according to Table 10.

The conductors are connected and disconnected five times, new conductors being used each time. After each connection the conductors are subjected to a pull, without jerks, for 1 min in the axis of the tapping conductor according to the value given in Table 14.

#### Pass criteria

During the test, there shall be no movement of the conductor in the terminal or any sign of damage.

#### 8.4.2.3.2 Pull test on terminals designed for multi-core cables or cords

The pull-out test on the SPD terminals designed for multi-core cables or cords is carried out as for single core conductors, except that the pull force is applied to the entire multi-core cable or cord instead of to the individual core.

The pull force is calculated according to the following formula:

$$F = F(x) \sqrt{n}$$

where

$F$  is the total force to apply;

$n$  is the number of cores;

$F(x)$  is the force for one core according to the cross-section of one conductor (see Table 14).

During the test, the cable or cord shall not slip out of the terminals.

#### 8.4.2.4 Flat quick connect terminations

Under consideration.

#### 8.4.2.5 Pigtail connections (flying leads)

##### 8.4.2.5.1 Pull test on flying lead conductors

Compliance of an integral flying lead, intended to be connected in the field to the power system, shall be checked by the following tests.

A flying lead and anchorages shall withstand without damage or detachment a direct pull of 89 N for one minute, applied to the lead from any angle which the construction or the device will allow.

#### Pass criteria

During the test, there shall be no movement of the conductor or any sign of damage.

#### 8.4.3 Verification of air clearances and creepage distances

SPDs for domestic and similar applications shall be designed for pollution degree 2.

SPDs for more stringent environmental applications may require special precautions, e.g. an appropriate SPD housing or an additional enclosure, which will ensure pollution degree 2 for the SPDs.

NOTE SPD-housings without ventilation openings are considered to provide adequate protection to limit the pollution sufficiently to allow the application of pollution degree 2 requirement to internal creepage distances.

For SPDs for outdoor and out of reach applications pollution degree 4 applies. This may be reduced to pollution degree 3 for internal distances, if they are covered by an adequate housing ensuring pollution degree 3 conditions.

The electrode spacing of spark gaps shall not be considered for the determination of air clearances and creepage distances.

#### Pass criteria

The air clearances and creepage distances shall not be smaller than the values indicated in Table 15 and Table 16.

NOTE For altitudes exceeding 2 000m refer to IEC 60664-1:2007, Table F.2, and use  $U_{\max}$  as input parameter to the columns for Case A – in homogeneous field conditions, to determine the required clearances. But in any case, the minimum requirements according Table 15 of this standard should be fulfilled for mechanical reasons.

Table 15 – Air clearances for SPDs

$U_{\max}^a$	$\leq 2\,000\text{ V}$	$\leq 4\,000\text{ V}$	$>4\,000\text{ V}$ up to $6\,000\text{ V}$	$>6\,000\text{ V}$ up to $8\,000\text{ V}$
<b>Air clearances in millimetres</b>				
1) Between live parts of different polarity	1,5	3	5,5	8
2) Between live parts and				
– screws and other means to fasten a covering, having to be detached for mounting the SPD	1,5	3	5,5	8
– fastening surfaces (NOTE 2)	3	6	11	16
– screws or other means for fastening the SPD (NOTE 2)	3	6	11	16
– bodies (NOTES 1 and 2)	1,5	3	5,5	8
3) Between the metal parts of the disconnecter mechanism and				
– bodies (NOTE 1)	1,5	3	5,5	8
– screws or other means for fastening the SPD	1,5	3	5,5	8
<sup>a</sup> This column is only applicable for SPDs with $U_C$ lower or equal to 180 V.				
NOTE 1 For definition, see 8.3.6 a)				
NOTE 2 If clearances between live parts of the device and the metallic screen or the surface on which the SPD is mounted are dependent on the design of the SPD only and cannot be reduced when the SPD is mounted in the least favourable position (even in a metallic enclosure), the values of line 1) are sufficient.				

**Table 16 – Creepage distances for SPDs**

r.m.s. voltage <i>b, c</i>	Minimum creepage distances in millimetres								
	Printed wiring material		Pollution degree						
	Pollution degree		1	2			3		
	1	2		All material groups	Material group <sup>a</sup>			Material group <sup>a</sup>	
<i>v</i>	All material groups	All material groups, except IIIb	All material groups	I	II	III	I	II	III <sup>d</sup>
10	0,025	0,04	0,08	0,4	0,4	0,4	1	1	1
12,5	0,025	0,04	0,09	0,42	4,42	4,42	1,0	1,05	1,05
16	0,025	0,04	0,1	0,45	0,45	0,45	1,1	1,1	1,1
20	0,025	0,04	0,11	0,48	0,48	0,48	1,2	1,2	1,2
25	0,025	0,04	0,125	0,5	0,5	0,5	1,2	1,25	1,25
32	0,025	0,04	0,14	0,53	0,53	0,53	1,3	1,3	1,3
40	0,025	0,04	0,16	0,56	0,8	1,1	1,4	1,6	1,8
50	0,025	0,04	0,18	0,6	0,85	1,2	1,5	1,7	1,9
63	0,04	0,063	0,2	0,63	0,9	1,25	1,6	1,8	2
80	0,063	0,1	0,22	0,67	0,95	1,3	1,7	1,9	2,1
100	0,1	0,16	0,25	0,71	1	1,4	1,8	2	2,2
125	0,16	0,25	0,28	0,75	1,05	1,5	1,9	2,1	2,4
160	0,25	0,4	0,32	0,8	1,1	1,6	2	2,2	2,5
200	0,4	0,63	0,42	1	1,4	2	2,5	2,8	3,2
250	0,56	1	0,56	1,25	1,8	2,5	3,2	3,6	4
320	0,75	1,6	0,75	1,6	2,2	3,2	4	4,5	5
400	1	2	1	2	2,8	4	5	5,6	6,3
500	1,3	2,5	1,3	2,5	3,6	5	6,3	7,1	8
630	1,8	3,2	1,8	3,2	4,5	6,3	8	9	10
800	2,4	4	2,4	4	5,6	8	10	11	12,5
1 000	3,2	5	3,2	5	7,1	10	12,5	14	16

<sup>a</sup> For further information on material groups refer to Table 17.

<sup>b</sup> This voltage is  
for functional insulation, the working voltage;  
for basic and supplementary insulation of the circuit energized directly from the supply mains, the voltage rationalized through Table F.3a or Table F.3b of IEC 60664-1, based on the rated voltage of the equipment, or the rated insulation voltage;  
for basic and supplementary insulation of systems, equipment and internal circuits not energized directly from the mains, the highest r.m.s. voltage which can occur in the system, equipment or internal circuit when supplied at rated voltage and under the most onerous combination of conditions of operation within equipment rating.

<sup>c</sup> For the main protection circuit, this column refers to  $U_C$ .

<sup>d</sup> Material IIIb shall not be used for application in pollution degree 3 above 630 V.

**NOTE** If the actual voltage differs from the values given in the table, it is allowed to interpolate values for intermediate voltages. When interpolating, linear interpolation should be used and values should be rounded to the same number of digits than the values picked from the table.

**Table 17 – Relationship between material groups and classifications**

<b>Material group I</b>	<b><math>600 \leq \text{CTI}</math></b>
<b>Material group II</b>	<b><math>400 \leq \text{CTI} &lt; 600</math></b>
<b>Material group IIIa</b>	<b><math>175 \leq \text{CTI} &lt; 400</math></b>
<b>Material group IIIb</b>	<b><math>100 \leq \text{CTI} &lt; 175</math></b>
Relationship between material groups and classifications are according to IEC 60112 (CTI values, using solution A).	

The measurements are carried out without conductors as well as with conductors of the greatest cross-sectional area indicated by the manufacturer. Nuts and screws with out-of-round heads are assumed to be in the least favourable tightening position.

If there is a partition, the air clearance is measured across the partition; where the partition consists of two parts which are not joined together, the air clearance is measured through the separating gap. Distances due to slits or holes in outer parts out of isolating material are measured against a metal foil on the touchable surface: for this purpose the foil is not pressed into the holes, but it shall be pushed into corners and similar by means of the test finger according IEC 60529.

In the case that there is a cavity in the course of the creepage distance, its profile is only considered if it is at least 1mm wide; cavities smaller than 1 mm are only considered in their width.

In the case that there is a partition made out of two parts which are not glued together, the creepage distance is measured through the separating gap. If the air gap between a live part and a partition with fitting surfaces is smaller than 1 mm, only the distance through the separating surface is considered, which is then looked upon as creepage distance. If not, the whole distance, namely the sum out of air gap and the distance through the separating surface, is taken as air clearance. If metal parts are covered with self-hardening resin of a least 2 mm thickness, or if they are covered with an insulation, withstanding a test voltage according to 8.3.7, creepage distances and air clearances are not necessary.

Casting material or resin shall not come over the rim of the cavity, it shall adhere to the walls of the cavity and the metal parts in it.

This is tested by examination and attempting to detach the casting material or resin without use of a tool.

#### **8.4.4 Mechanical strength**

##### **8.4.4.1 Impact test**

SPDs shall have adequate mechanical strength so as to withstand the stresses imposed during installation and use.

Compliance is checked by the appropriate tests as follows:

The samples are subjected to strikes by means of an impact-test apparatus as shown in Figure 18 and Figure 19.

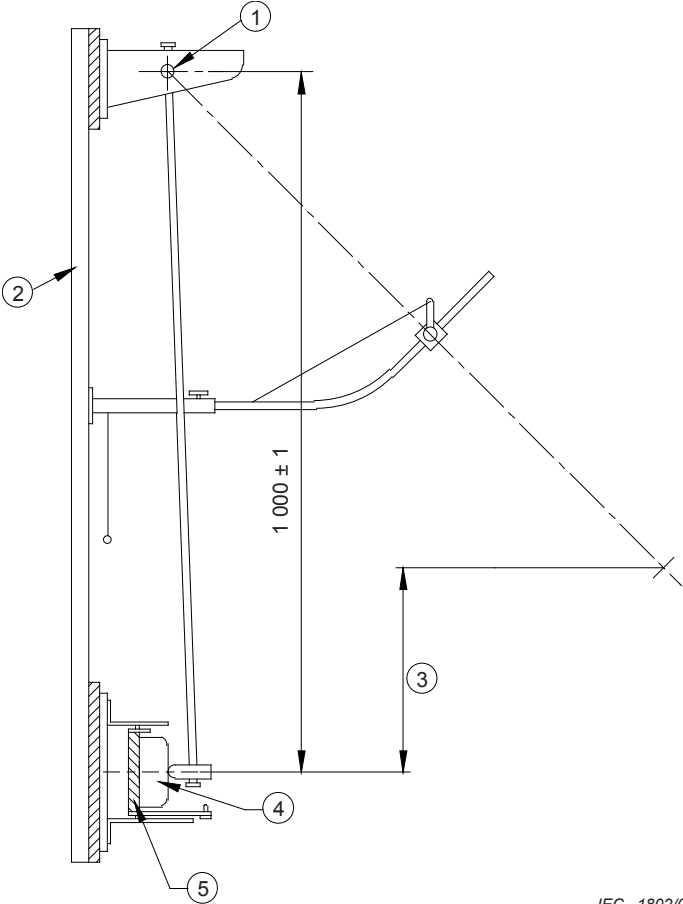

IEC 1802/01

*Dimensions in millimetres*

**Key**

- 1 Pendulum
- 2 Frame
- 3 Height of fall
- 4 Specimen
- 5 Mounting fixture

**Figure 18 – Test apparatus for impact test**

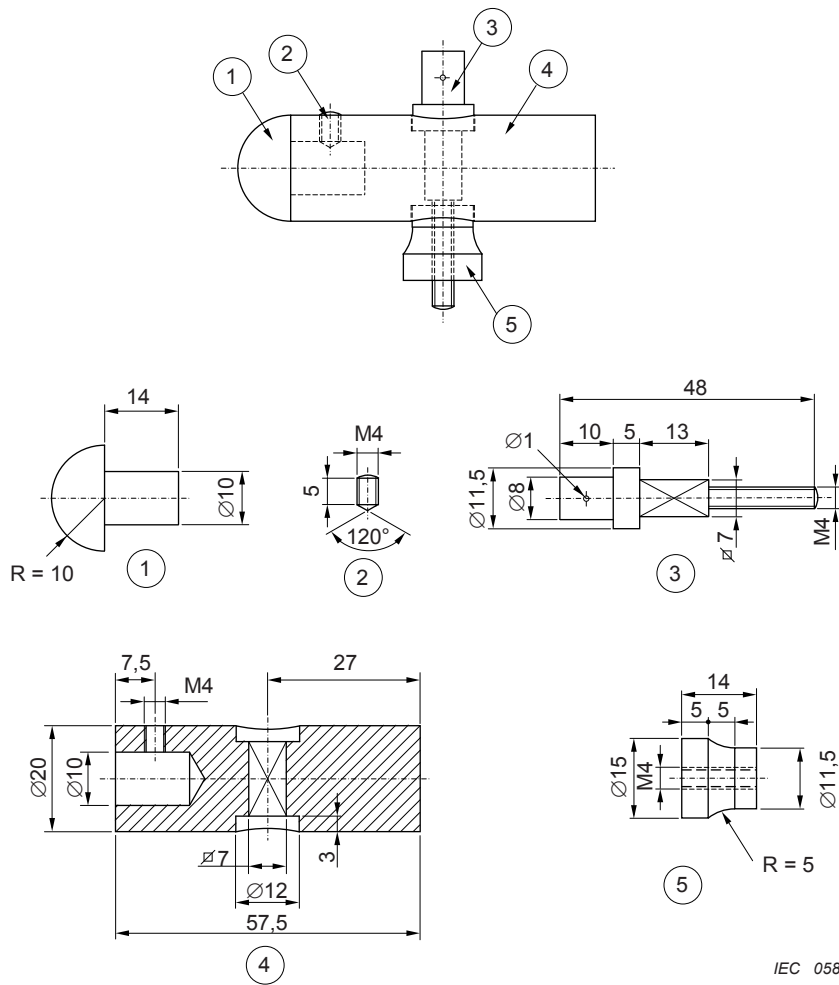

IEC 058/09

Dimensions in millimetres

**Key:**

1 Polyamide

2, 3, 4, 5 Steel Fe 360

**Figure 19 – Striking element of the pendulum hammer**

The striking element has a hemispherical face, 10 mm radius, made of polyamide having a Rockwell hardness of HR 100, and has a mass of 150 g ± 1 g.

It is rigidly fixed to the lower end of a steel tube with an external diameter of 9 mm and a wall thickness of 0,5 mm, which is pivoted at its upper end in such a way that it swings only in a vertical plane.

The axis of the pivot is 1 000 mm ± 1 mm above the axis of this striking element.

The Rockwell hardness of the polyamide striking element is determined by using a ball having a diameter of 12,700 mm ± 0,0025 mm, the initial load 100 N ± 2 N and the extra load 500 N ± 2,5 N.

NOTE Additional information concerning the determination of the Rockwell hardness of plastics is given in ISO 2039-2.

The design of the apparatus is such that a force of between 1,9 N and 2,0 N has to be applied to the face of the striking element to maintain the tube in a horizontal position.

The samples are mounted on a sheet of plywood, 8 mm thick and 175 mm square, secured at its top and bottom edges to a ridged bracket.

Portable SPDs are tested as fixed SPDs, but they are fixed to the plywood sheet by auxiliary means.

The mounting support shall have a mass of 10 kg ± 1 kg and shall be mounted on a rigid frame.

The design of the mounting is such that

- the sample can be so placed that the point of impact lies in the vertical plane through the axis of the pivot,
- the sample can be displaced horizontally and turned about an axis perpendicular to the surface of the plywood,
- the plywood can be turned around a vertical axis.

Flush-type SPDs are mounted in a recess provided in a block of hornbeam or material having similar mechanical characteristics, which is fixed to a sheet of plywood. (They are not tested in their relevant mounting boxes.)

If wood is used for the block, the direction of the wood fibres shall be perpendicular to the direction of the impact.

Flush-type screw fixing SPDs shall be fixed by means of screws to lugs recessed in the block. Flush-type claw fixing SPDs shall be fixed to the block by means of the claws.

Before applying the strikes, fixing screws of bases and covers are tightened with a torque equal to two-thirds of that specified in Table 10.

The samples are mounted so that the point of impact lies in the vertical plane through the axis of the pivot.

The striking element is allowed to fall from a height which is specified in the following Table 18.

**Table 18 – Fall distances for impact requirements**

Height of fall mm	Parts of enclosures to be subjected to the impacts	
	Ordinary accessory	Other accessories
100	A and B	A and B
150	C	C
200	D	D

A: parts on the front surface, including parts which are recessed.  
 B: parts which do not project more than 15 mm from the mounting surface (distance from the wall) after mounting as in normal use, with the exception of the above parts A.  
 C: parts which project more than 15 mm and not more than 25 mm from the mounting surface (distance from the wall) after mounting as in normal use, with the exception of the above parts A.  
 D: parts which project more than 25 mm from the mounting surface (distance from the wall) after mounting as in normal use, with the exception of the above parts A.

The heights of the fall determined by the part of the sample which projects most from the mounting surface is applied on all parts of the sample, with the exception of parts A.

The height of fall is the vertical distance between the position of a checking point when the pendulum is released, and the position of that point at the moment of impact. The checking point is marked on the surface of the striking element where the line through the point of intersection of the axes of the steel tube of the pendulum and the striking element and perpendicular to the plane through both axes, meets the surface.

The samples are subjected to strikes which are evenly distributed over the samples. The strikes are not applied to "knock-out" areas.

The following blows are applied:

- for parts A, five strikes: one in the centre. After the sample has been moved horizontally: one each on the unfavourable points between the centre and the edges; and then, after the sample has been turned 90° about its axis perpendicular to the plywood, one each on similar points;
- for parts B (as far as applicable), C and D, four blows:
  - one on one side of the sample after the plywood sheet has been turned 60° and one blow on another side of the sample after it has been turned 90° about its axis perpendicular to the plywood sheet, keeping the position of the plywood sheet unchanged;
  - one blow on each of the other two sides of the sample, with the plywood sheet turned 60° in the opposite direction.

#### **Pass criteria**

After the test the sample shall show no damage within the meaning of the standard. In particular live parts shall not become accessible with the standard test finger.

Damage to the finish small dents which do not reduce creepage distances or clearances and small chips which do not adversely affect the protection against electric shock or harmful ingress of water are neglected.

Cracks not visible with the normal or corrected vision, without additional magnification, and surface cracks in fibre reinforced mouldings and the like are ignored.

### **8.5 Environmental and material tests**

#### **8.5.1 Resistance to ingress of solid objects and to harmful ingress of water**

Testing shall be carried out in accordance with IEC 60529 to check the IP code.

#### **8.5.2 Heat resistance**

The SPD is kept in a heated cabinet at a temperature of 100 °C ± 2 K for the duration of 1 h.

#### **Pass criteria**

The pass criteria **C** and **I** according to Table 4 and the following additional pass criteria shall apply:

- any sealing compound (including potting) used in the internal assembly shall not move to such an extent as to create a problem for the functionality of the SPD
- the SPD is deemed to have passed the test even if a disconnecter has opened.

### 8.5.3 Ball pressure test

Outer parts of SPDs, consisting of insulating material, are submitted to a ball pressure test by means of a tester as shown on Figure 20 and Figure 21.

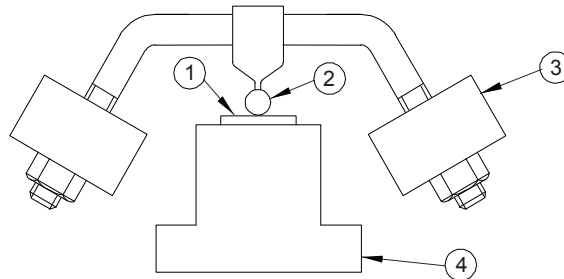

IEC 219/11

#### Key

- 1 Test specimen
- 2 Pressure ball
- 3 Weight
- 4 Specimen support

Figure 20 – Ball thrust tester

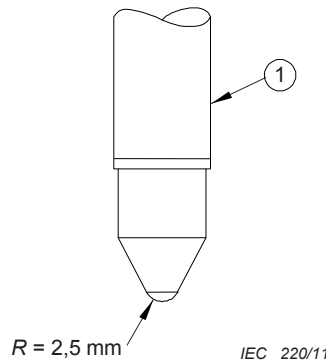

IEC 220/11

#### Key

- 1 Loading rod

Figure 21 – Loading rod for ball thrust tester

Parts of insulating material necessary to retain current carrying parts and parts of the earthing circuit in position are tested in a heating cabinet at  $125\text{ °C} \pm 2\text{ K}$ .

Parts of insulating material not necessary to retain current carrying parts and parts of the earthing circuit in position, even though they are in contact with them, are tested at  $70\text{ °C} \pm 2\text{ K}$ .

The sample to be tested is fastened accordingly, its surface being positioned horizontally; a steel ball having a diameter of 5 mm is pressed against the surface with a force of 20 N.

After 1 h, the steel ball is taken away from the sample; by dipping it into cold water, the temperature of the sample is reduced to ambient temperature within 10 s.

#### **Pass criteria**

The diameter of the ball indentation is measured and shall not exceed 2 mm.

NOTE Ceramic parts are not submitted to this test.

#### **8.5.4 Resistance to abnormal heat and fire**

The glow wire test is performed in accordance with Clauses 4 to 10 of IEC 60695-2-11 under the following conditions:

- for external parts of SPDs made of insulating material necessary to retain in position current-carrying parts and parts of the protective circuit, by the test made at a temperature of  $850\text{ °C} \pm 15\text{ K}$ ;
- for all other external parts made of insulating material, by the test made at a temperature of  $650\text{ °C} \pm 10\text{ K}$ .

The test is not made on parts of ceramic material and parts with lower size than defined in 3.1 of IEC 60695-2-11.

If the insulating parts are made of the same material, the test is carried out only on one of these parts, according to the appropriate glow-wire test temperature.

The glow-wire test is applied to ensure that an electrically heated test wire under defined test conditions does not cause ignition of insulating parts, or to ensure that a part of insulating material, which might be ignited by the heated test wire under defined conditions, has a limited time to burn without spreading fire by flame or burning parts or droplets falling down from the tested part.

The test is made on one sample.

In case of doubt, the test is repeated on two additional samples.

The test is made by applying the glow-wire once.

The sample shall be positioned during the test in the least favourable position of its intended use (with the surface tested in a vertical position).

The tip of the glow-wire shall be applied to the specified surface of the test sample taking into account the conditions of intended use under which a heated or glowing element may come into contact with the sample.

#### **Pass criteria**

The sample is regarded as having passed the glow-wire test if

- there is no visible flame and no sustained glowing, or if
- flames and glowing parts on the sample extinguish themselves within 30 s after the removal of the glow-wire.

There shall be no ignition of the tissue paper or scorching of the pinewood board.

### 8.5.5 Tracking resistance

The test is performed according to IEC 60112, solution A with a test voltage depending on the measured creepage distances and the required material group according 8.4.3.

## 8.6 Additional tests for specific SPD designs

### 8.6.1 Test for two-port SPDs and one-port SPDs with separate input/output terminals

#### 8.6.1.1 Rated load current ( $I_L$ )

The SPD shall be powered at a voltage  $U_c \begin{smallmatrix} 0 \\ -5 \end{smallmatrix}$  % at ambient temperature, using a cable with a nominal cross-section as specified in Table 19. The test shall be conducted with rated load current into a resistive load until thermal stability is reached. Additional cooling of the SPD is not permitted.

**Table 19 – Test conductors for rated load current test**

Test current [A]		Cross section	
Greater than	Less or equal	[mm <sup>2</sup> ]	AWG/MCM
0	8	1,0	18
8	12	1,5	16
12	15	2,5	14
15	20	2,5	12
20	25	4,0	10
25	32	6,0	10
32	50	10	8
50	65	16	6
65	85	25	4
85	100	35	3
100	115	35	2
115	130	50	1
130	150	50	0
150	175	70	00
175	200	95	000
200	225	95	0000
225	250	120	250
250	275	150	300
275	300	185	350
300	350	185	400
350	400	240	500

NOTE If other standardized cross-sections are used in specific countries, the next closest cross-section should be used for testing.

### Pass criteria

The pass criteria **C**, **F** and **G** according to Table 4 and the following additional pass criteria apply.

The temperature rise of surfaces which are accessible in normal use shall not exceed the values described in Annex G during the test.

**8.6.1.2 Overload behaviour**

The test is carried out at ambient temperature and the sample shall be protected against abnormal external heating or cooling.

The test circuit and procedure shall be as described in 8.6.1.1, except that circuits other than the main circuit are disregarded for this test.

The test is performed without any external disconnectors being connected (internal removable overcurrent protective devices are replaced by a link of negligible impedance).

If a maximum overcurrent protection is specified by the manufacturer, the SPD shall be loaded for 1 h with a current equal to  $k$  times that maximum overcurrent protection. The factor  $k$  shall be selected from Table 20.

**Table 20 – Current factor  $k$  for overload behaviour**

Protective device	Trip current factor $k$
Circuit breaker	1,45
Fuse	1,6
<p>NOTE 1 If the type of protective device (breaker or fuse) is not specified by the manufacturer, the test is performed with the higher <math>k</math> factor.</p> <p>NOTE 2 For countries using other values, these values should be declared on the SPD's data sheet according to 7.1.1 c7).</p> <p>NOTE 3 National condition for Japan: <math>k</math> is 1,25 for circuit-breaker and 1,5 for fuse.</p> <p>NOTE 4 National condition for North America: <math>k</math> is under consideration.</p>	

If no maximum overcurrent protection is specified by the manufacturer, the SPD shall be loaded with 1,1 times the rated load current for 1 h or until an internal disconnector operates. If no disconnector operates within 1 h, the test is continued by increasing the previous value of test current by a factor of 1,1 every hour, until an internal disconnector operates.

**Pass criteria**

a) Any internal disconnector has operated:

The pass criteria **C**, **H**, **I**, **J** and **M** according to Table 4 shall apply.

b) No internal disconnector has operated:

The pass criteria **C**, **D**, **E**, and **I** according to Table 4 shall apply.

In addition the temperature rise of surfaces which are accessible in normal use shall not exceed the values described in Annex G during the test.

**8.6.1.3 Load-side short-circuit current behaviour test**

This test applies to all SPDs, except those classified for outdoor use and mounted out of reach and those connected N-PE for use in TN and/or TT systems only.

The test settings and the test procedure according to 8.3.5.3 (excluding 8.3.5.3.1) are repeated without short-circuiting any components, but with a short-circuit link connected to the following output terminals of the SPD as applicable:

- short-circuit link across all phase terminals and the neutral terminal (if applicable) on the load side,
- short-circuit link across all terminals on the load side,

with a conductors of the largest cross-section specified under 8.4.2 and with a length of 500 mm each.

An example of appropriate test circuits is given in Figure 22

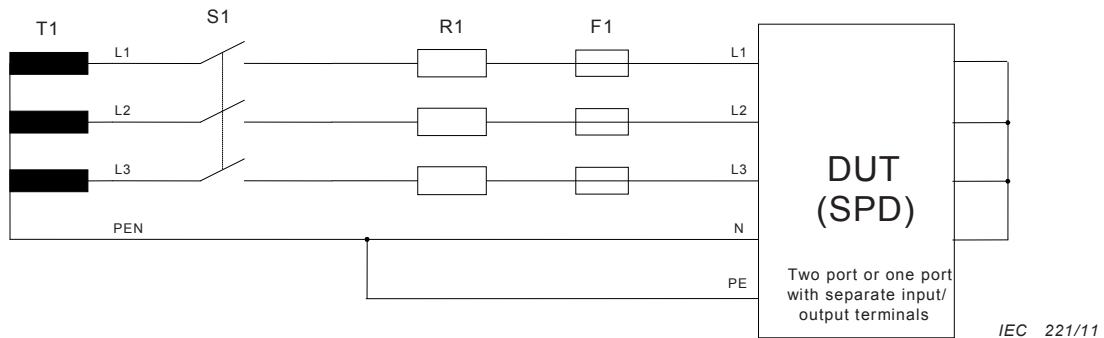

**a) Test with all phase terminals and the neutral terminal short-circuited on the load side**

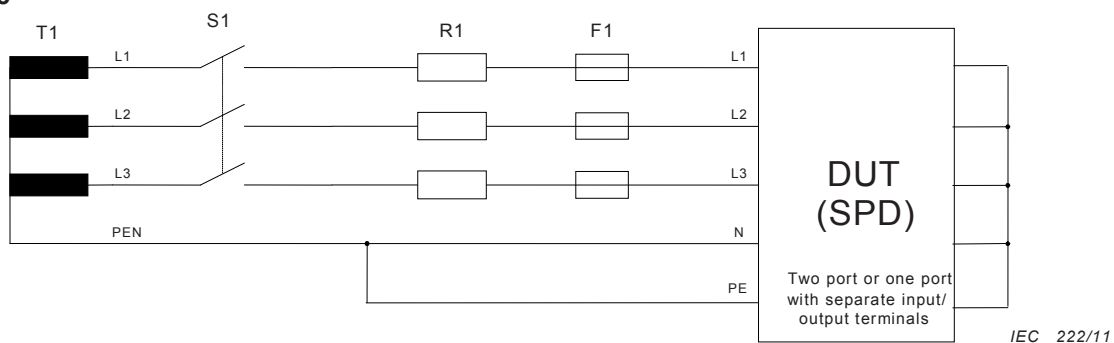

**b) Test with all terminals short-circuited on the load side**

**Key**

S1	Main switch for synchronised initiation of the short-circuit
F1	All disconnectors required by the manufacturer, including the maximum recommended overcurrent protection according to manufacturers instructions
T1	Power supply transformer with a secondary voltage at $U_{REF}$
R1	Current limiting resistor to adjust the prospective short-circuit current of the power supply
DUT	Device under test

**Figure 22 – Examples for appropriate test circuits of the load side short-circuit test(s)**

**Pass criteria**

The pass criteria **C**, **E**, **H**, **I**, **J**, **K**, **M** and **N** according to Table 4 and the following additional pass criteria shall apply.

**a) Internal disconnector(s) have operated:**

- After removing the short-circuit links from output terminals and with  $U_{REF}$  applied according to the circuit shown in Figure 22, there shall be no voltage on the output terminals.
- With a power frequency voltage equal to two times  $U_C$  applied between all corresponding input and output phase terminals for 1 min there shall be no current flow in excess of 0,5 mA.

**b) No internal disconnector has operated:**

- The pass criteria **D** according to Table 4 shall apply.

## 8.6.2 Environmental tests for outdoor SPDs

See informative Annex F.

## 8.6.3 SPDs with separate isolated circuits

The isolation and dielectric withstand of the separate circuits shall be tested based on the manufacturer's declaration and in accordance with 8.3.6 and 8.3.7.

## 8.6.4 Short-circuiting type SPDs

For such SPD's a conditioning into an intentional short-circuit according 8.6.4.1 is carried out, followed by a surge withstand test according 8.6.4.2 and a short-circuit current behaviour test according 8.6.4.3.

### 8.6.4.1 Change of characteristic procedure (conditioning test)

One impulse of  $I_{trans}$  with positive polarity is applied to the de-energised SPD to change of characteristic of the SPD into an internal short-circuit. To check for the internal short-circuit an appropriate measurement shall be performed after this test.

### 8.6.4.2 Surge withstand test (in short-circuited condition)

One impulse of  $I_{trans}$  with positive polarity is applied to the de-energised SPD.

#### Pass criteria

The pass criteria **C**, **I** and **M** according to Table 4 shall apply

### 8.6.4.3 Short-circuit current behaviour test (in short-circuited condition)

#### Test settings

The test is performed according to 8.3.5.3 excluding 8.3.5.3.1 and 8.3.5.3.2, but without any sample preparation.

#### Pass criteria

The pass criteria **C**, **H**, **I**, **J**, **K**, **M** and **N** according to Table 4 shall apply

## 8.7 Additional tests for specific performance if declared by the manufacturer

### 8.7.1 Total discharge current test for multipole SPDs

#### Test settings

One side of the test generator is connected to the PE or PEN terminal of the multipole SPD. Each of the remaining SPD terminals is connected via a typical series impedance consisting of a resistance of 30 mΩ and an inductance of 25 μH, to the other side of the generator.

NOTE 1 These impedances simulate the connection to the power system and should not be increased by the measuring system, e.g. shunts.

NOTE 2 This test configuration does not represent all system configurations. Specific schemes or applications may require other testing procedures.

Smaller impedances may be used if the tolerances for the proportional surge currents according to Table 21 are met.

NOTE 3 The proportional surge current is the total discharge current divided by N, where N represents the number of live terminals (phases and neutral).

**Table 21 – Tolerances for proportional surge currents**

Test classification	Proportional currents and tolerances
Test class I	$I_{imp(1)} = I_{imp(2)} = I_{imp(N)} = I_{Total(imp)} / N \quad 10 \%$ $Q_{(1)} = Q_{(2)} = Q_{(N)} = Q_{Total} / N \quad -10/+20 \%$ $W/R_{(1)} = W/R_{(2)} = W/R_{(N)} = W/R_{Total} / N^2 \quad -10/+45 \%$
Test class II	$I_{8/20(1)} = I_{8/20(2)} = I_{8/20(N)} = I_{Total(8/20)} / N \quad \pm 10\%$

### Test procedure

The multipole SPD shall be tested once with the total discharge current  $I_{Total}$  declared by the manufacturer.

### Pass criteria

The pass criteria **B, C, D, E, G, I** and **M** according to Table 4 shall apply

#### 8.7.2 Test to determine the voltage drop

A voltage  $U_c$  is supplied at the input port and shall be constant within  $-5 \%$ . The test shall be conducted with rated load current into a resistive load. Input and output voltage shall be measured simultaneously with load connected. Use the following formula to determine the voltage drop.

$$\Delta U \% = ((U_{in} - U_{out}) / U_{in}) 100 \%$$

where

$U_{in}$  is the input voltage and  $U_{out}$  is the output voltage measured simultaneously with a full rated resistive load connected. This parameter is only used for two-port SPDs.

Other measuring techniques are permitted provided they achieve comparable results.

### Pass criteria

This value shall be recorded and comply with the manufacturer's declaration.

#### 8.7.3 Load-side surge withstand capability

For this test:

- 15 current impulses 8/20, or
- 15 combination wave impulses with an open-circuit voltage  $U_{oc}$

with a value equal to the load-side surge withstand capability declared by the manufacturer are applied in three groups of five impulses to the output port of the test sample. The SPD is energized at  $U_c$  by means of a voltage source having a nominal current of at least 5 A. Each impulse shall be synchronized to the power frequency. Starting from  $0^\circ$  the synchronization angle shall be increased in steps of  $(30 \pm 5)^\circ$ .

The interval between the impulses is 50 s to 60 s and the interval between the groups is 30 min to 35 min.

The test sample shall be energized during the whole test sequence. The voltage on the output terminals shall be recorded.

### Pass criteria

The pass criteria **A, B, C, D, E, F** and **G** according to Table 4 shall apply

#### 8.7.4 Measurement of voltage rate of rise $du/dt$

This test is performed on a de-energised two port SPD terminated with a resistive load, which would cause a current equal to 0,1 times the rated load current  $I_L$  at  $U_{REF}$ . A combination wave generator fulfilling the requirements of section 8.1.4 is connected to the input terminals of the two port device.

NOTE 1 During this test no power frequency source is applied to the SPD.

The generator is set to a  $U_{OC}$  of 6 kV, thereby providing an open circuit voltage rate of rise  $du/dt$  of approximately 5 kV/ $\mu$ s. A storage oscilloscope is connected to the output terminals of the two port SPD and the resultant wave shape recorded on application of the test impulse.

The maximum voltage rate of rise  $du/dt$ , is determined by measuring the difference in voltage and time between the  $t_{90}$  and the  $t_{30}$  points on the rising edge of the resultant waveform.

NOTE 2  $t_{90}$  and  $t_{30}$  are the 90 % and 30 % points on the leading edge of the waveform.

To accommodate the possibility of ringing on the wavefront, this test should be performed five times and the maximum  $du/dt$  recorded.

#### Pass criteria

The maximum voltage rate-of-rise shall be recorded and shall comply with the manufacturer's declaration.

## 9 Routine and acceptance tests

### 9.1 Routine tests

Appropriate test(s) are performed during manufacturing production to verify that the SPD is capable of meeting its performance. The manufacturer shall declare the test method(s).

### 9.2 Acceptance tests

Acceptance tests are made upon agreement between manufacturer and purchaser. When the purchaser specifies acceptance tests in the purchase agreement, the following tests shall be made on the nearest lower whole number to the cube root of the number of SPDs to be supplied. Any alteration in the number of test samples or type of test shall be negotiated between the manufacturer and the purchaser.

If not otherwise specified, the following tests are specified as acceptance tests:

- a) verification of identification by inspection as per 8.2;
- b) verification of marking by inspection as per 8.2;
- c) verification of electrical parameters (e.g. measured limiting voltage as per 8.3.3).

## **Annex A** (normative)

### **Reference test voltages for SPDs $U_{REF}$**

The reference test voltage  $U_{REF}$  depends on the intended application of an SPD within a low-voltage power distribution system according to the installation instructions given by the manufacturer:

- type of LV systems (TN-system, TT-system, IT-system)
- intended connection (line to neutral, line to ground, neutral to ground, line to line)
- nominal a.c. system voltages and maximum allowed voltage regulation.

Table A.1 – Reference test voltage values

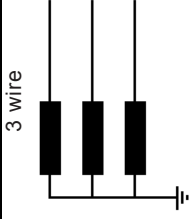
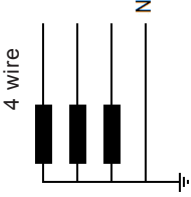
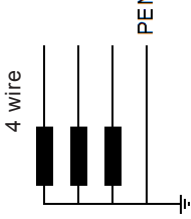
Power distribution system	Nominal AC system voltage L-PE / L-L V	Expected voltage regulation of the power distribution system max +(%)	Reference test voltage $U_{REF}$ (depending on the mode of protection) V			
			L - N (PEN)	L - PE	L - L	N - PE
Three phase TT-system Without PE and Neutral distribution 	230 / 400	10	---	440	---	
Three phase TT-system With Neutral distribution 	230 / 400	10	255	440	255	
Three phase TN-C system with PEN distribution 	230 / 400	10	255	440	---	

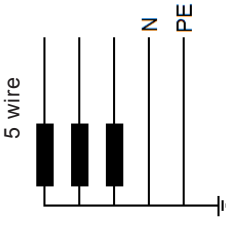
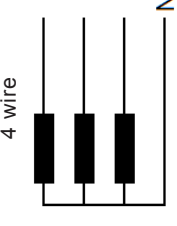
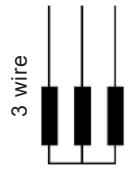
Power distribution system	Nominal AC system voltage L-PE / L-L V	Expected voltage regulation of the power distribution system max +(%)	Reference test voltage $U_{REF}$ (depending on the mode of protection) V			
			L - N (PEN)	L - PE	L - L	N - PE
Three phase TN-S-system with PE and neutral distribution 	230 / 400	10	255	255	440	255
	240 / 415	6	255	255	440	255
	120 / 208	10	132	132	230	50
Three phase IT-system with neutral distribution 	277 / 480	10	305	305	530	115
	230 / 400	10	440	440	255	255
Three phase IT-system without neutral distribution 	230	10	---	255	255	---

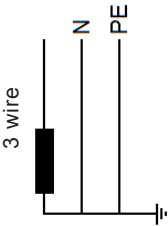
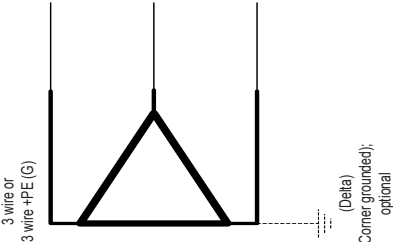
Power distribution system		Nominal AC system voltage L-PE / L-L V	Expected voltage regulation of the power distribution system max +(%)	Reference test voltage $U_{REF}$ (depending on the mode of protection) V			
				L - N (PEN)	L - PE	L - L	N - PE
Single phase TN-S-system		230	10	255	255	---	255
		120		132	132	---	132
Three phase (Delta) Corner grounded TN system or TT or IT system		230	10	---	264	264	---
		200 (202)		222	222	222	---
		460		528	528	528	---

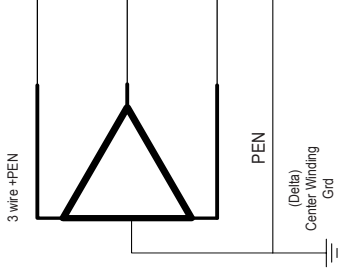
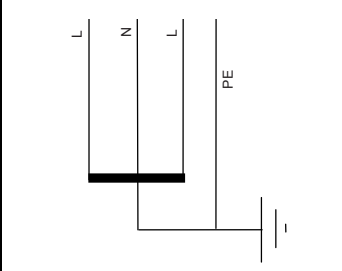
Power distribution system	Nominal AC system voltage L-PE / L-L V	Expected voltage regulation of the power distribution system max +(%)	Reference test voltage $U_{REF}$ (depending on the mode of protection) V			
			L - N (PEN)	L - PE	L - L	N - PE
Three phase (Delta) Central winding grounded TN system or TT system 	230	10	264	264	264	---
	200 (202)		129 192	222	---	---
	460		528	528	---	---
Split phase TN system 	120 / 240	10	132	264	132	132

NOTE If higher voltage regulation is required for certain applications (for example +15%), subject to a special agreement between the manufacturer and the user.

## Annex B (normative)

### TOV Ratings

The test procedure depends on the intended application of an SPD in a low-voltage power distribution system according to the installation instructions given by the manufacturer.

For systems defined in IEC 60364 series, values are given below in Table B.1.

**Table B.1 – TOV test values for systems complying with IEC 60364 series**

Application	TOV test parameters		
	SPDs connected to:	For $t_T=5$ s (LV-system faults in consumer installation) (requirement to 7.2.8.1 and test 8.3.8.1)	For $t_T=120$ min (LV-system faults in distribution system and loss of neutral (requirement to 7.2.8.1 and test 8.3.8.1)
	Withstand mode required	Withstand or safe failure mode acceptable	Withstand or safe failure mode acceptable
<b>TOV test values <math>U_T</math> (V)</b>			
<b>TN-systems</b>			
Connected L-(PE)N or L-N	$1,32 \times U_{REF}$	$\sqrt{3} \times U_{REF}$	
Connected N-PE			
Connected L-L			
<b>TT-systems</b>			
Connected L-PE	$\sqrt{3} \times U_{REF}$	$1,32 \times U_{REF}$	$1\ 200 + U_{REF}$
Connected L-N	$1,32 \times U_{REF}$	$\sqrt{3} \times U_{REF}$	
Connected N-PE			1 200
Connected L-L			
<b>IT-systems</b>			
Connected L-PE			$1\ 200 + U_{REF}$
Connected L-N	$1,32 \times U_{REF}$	$\sqrt{3} \times U_{REF}$	
Connected N-PE			$1\ 200 + U_{REF}$
Connected L-L			
$U_{REF}$	reference test voltage used for testing and taking into account the maximum voltage regulation of the power system (see Annex A).		
$U_o$	in TN- and TT-systems: nominal a.c. r.m.s. line voltage to earth; in IT-systems: nominal a.c. voltage between line conductor and neutral conductor or midpoint conductor, as appropriate (see 442.1.2 of IEC 60364-4-44:2007).		
$1,32 \times$	$U_{REF}$ equals $1,45 \times U_o$ in case the voltage regulation does not exceed +10 % (see 442.5 of IEC 60364-4-44:2007).		
<b>NOTE</b> As voltage regulation exceeds 10 % in some countries, only $U_{REF}$ is used in this standard for general applicability. Further information on voltage regulation can be found in IEC 60038.			

## **B.1 Special distribution system requirements**

Some countries require additional TOV test values and testing durations as given below.

For specific applications with conditions different than the ones given in Table B.1 and different from the special distribution system requirements given below, the TOV test values  $U_T$  and the testing duration may be defined by agreement between the manufacturer and the user, depending on actual network configurations and conditions. The values of  $U_T$  and the corresponding duration(s) shall be declared on the SPDs data sheet according to 7.1.1 c1).

For North American systems the values are given below in Table B.2.

### **Table B.2 – TOV test parameters for North American systems**

Values are under consideration

For Japanese system values are given below in Table B.3.

**Table B.3 – TOV test parameters for Japanese systems**

Application	TOV test parameters			
	LV system faults	HV system faults		
SPDs connected to:	for $t_T=120$ min	Not specified duration	for $t_T=2$ s	for $t_T=1$ s
	(LV-system faults in distribution system and loss of neutral (requirement to 7.2.8.1 and test 8.3.8.1))	Withstand or safe failure mode acceptable		
<b>TOV test values <math>U_T</math> [V]</b>				
<b>TN systems</b>				
Connected L-N(PE) or L-N	$\sqrt{3} \times U_{REF}$			
Connected N-PE				
Connected L-L				
<b>TT systems</b>				
Connected L-PE	$\sqrt{3} \times U_{REF}$	$150 + U_{REF}$	$300 + U_{REF}$	$600 + U_{REF}$
Connected L-N	$\sqrt{3} \times U_{REF}$			
Connected N-PE		150	300	600
Connected L-L				
<b>IT systems</b>				
Connected L-PE				$1\,200 + U_{REF}$
Connected L-N	$\sqrt{3} \times U_{REF}$			
Connected N-PE				$1\,200 + U_{REF}$
Connected L-L				
$U_{REF}$	reference test voltage used for testing and taking into account the maximum voltage regulation of the power system (see Annex A).			
NOTE 1 These values are required by ministerial ordinance of technical standards for electrical facilities.				
NOTE 2 As voltage regulation exceeds 10 % in some countries, $U_{REF}$ is used in this standard only for general applicability. Further information on voltage regulation can be found in IEC 60038.				

## Annex C (normative)

### Tests to determine the presence of a switching component and the magnitude of the follow current

These tests should be performed by the manufacturer to provide the information required according to 7.1.1 d1) and/or 7.1.1 d2).

#### C.1 Test to determine the presence of a switching (crowbar) component

This test has to be performed only if the internal design of the SPD is not known. A new sample shall be used for this test only.

The standard 8/20 current impulse is used for class I and class II tests of SPDs with a crest value according to  $I_n$  or  $I_{imp}$  as declared by the manufacturer. For class III test of an SPD, a combination wave generator shall be used with an open-circuit voltage equal to the  $U_{oc}$  declared by the manufacturer.

One impulse shall be applied to the SPD (in the case of a two-port SPD, the impulse shall be applied to its input and output terminals).

Oscillographic record of the voltage across the SPD shall be taken (in the case of a two-port SPD, the voltage measurement shall be taken across the input terminal of the SPD).

If the waveshape of the recorded voltage shows a sudden collapse, the SPD is considered as containing a switching (crowbar) component.

#### C.2 Test to determine the magnitude of the follow current

This test is intended to determine if the crest value of the follow current is above or below 500 A.

If the internal design and the crest value of the follow current of the SPD are known, this preliminary test is not required.

- a) The test shall be made with a separate test sample.
- b) The prospective short-circuit current shall be  $I_p = 1,5 \text{ kA}$  with a power factor  $\cos \varphi = 0,95 \begin{smallmatrix} 0 \\ -0,05 \end{smallmatrix}$ .
- c) It is connected to a power frequency voltage source with sinusoidal a.c. voltage. The power frequency voltage measured at the terminals, shall be the maximum equal to the continuous maximum operating voltage  $U_{C-5}^0$  %. The frequency of the a.c. voltage source shall correspond to the rated frequency of the SPD.
- d) The follow current shall be initiated with an impulse current 8/20 or a combination wave.
- e) The crest value shall correspond to  $I_n$ ,  $I_{imp}$  or  $U_{oc}$ .
- f) The current impulse shall be initiated 60 electrical degrees before the crest of the power frequency voltage. Its polarity shall coincide with the polarity of the half wave of the power frequency voltage in which it is initiated.

- g) If at this synchronization point there is no follow current, then the impulse current 8/20 has to be initiated later in steps of 10 electrical degrees each in order to determine if a follow current is generated.

## **Annex D** (normative)

### **Reduced test procedures**

Number of samples to be submitted and test sequence to be applied for verification of conformity.

For products already tested according to IEC 61643-1:2005, the simplified test procedure according to Table D.1 may be applied.

For new products, complete type tests and samples according to Clause 7 and Table 3 are required.

Table D.1 – Reduced test procedure for SPDs complying with IEC 61643-1:2005

Test sequence	Test description	Subclause	Testing required
<b>1</b>	Identification and marking	7.1.1/7.1.2/8.2	Yes
	Mounting	7.3.1	No
	Terminals and connections	7.3.2/7.3.3/8.4.2	No
	Testing for protection against direct contact	7.2.1/8.3.1	No
	Environment, IP code	7.4.1 / 8.5.1	No
	Residual current	7.2.2 / 8.3.2	Yes
	Operating duty test	7.2.4/8.3.4	No
	Operating duty test for test classes I, II and III	8.3.4.2 / 8.3.4.3/ 8.3.4.5	No
	Additional duty test for test class I	8.3.4.4	No
	Thermal stability	7.2.5.2 / 8.3.5.2	Yes
	Air clearances and creepage distances	7.3.4 / 8.4.3	Yes
	Ball pressure test	7.4.2 / 8.5.3	No
	Resistance to abnormal heat and fire	7.4.3 / 8.5.4	No
	Tracking resistance	7.4.4 / 8.5.5	No
<b>2</b>	Voltage Protection level	7.2.3/8.3.3	No
	Residual voltage	8.3.3.1	No
	Front of wave sparkover voltage	8.3.3.2	No
	Limiting voltage with combination wave	8.3.3.3	No
<b>2a</b>	See below - only if applicable		
<b>2b</b>	See below - only if applicable		
<b>3</b>	Insulation resistance	7.2.6 / 8.3.6	No
	Dielectric withstand	7.2.7 / 8.3.7	No
<b>3a</b>	See below - only if applicable		
<b>3b</b>	Mechanical strength	7.3.5 / 8.4.4	No
	Temperature withstand	7.2.5 / 8.3.5.1	No
<b>3b</b>	See below - only if applicable		
<b>3c</b>	See below - only if applicable		
<b>4<sup>c</sup></b>	Heat resistance	7.4.2 / 8.5.2	No
	TOV tests	7.2.8 / 8.3.8	Yes
	TOVs caused by faults in the low voltage system	7.2.8.1 / 8.3.8.1	Yes
	TOVs caused by faults in the high voltage system	7.2.8.2 / 8.3.8.2	Yes
<b>5<sup>c</sup></b>	Short-circuit current behaviour tests	7.2.5 / 8.3.5.3	Yes

Test sequence	Test description	Subclause	Testing required
<b>3c<sup>c</sup></b>	Rated load current	7.5.1.1 / 8.6.1.1	Yes
	Overload behaviour	7.5.1.2 / 8.6.1.2	Yes
<b>2b</b>	Load side short-circuit current behaviour	7.5.1.3 / 8.6.1.3	Yes
<b>3b</b>	Voltage drop	7.6.2.1 / 8.7.2	No
<b>2a<sup>c</sup></b>	Load side surge withstand	7.6.2.2 / 8.7.3	Yes
	Load side short-circuit current behaviour test	7.5.1.3 / 8.6.1.3	Yes
<b>6</b>	Total discharge current test for multipole SPDs	7.6.1.1 / 8.7.1	Yes
<b>7</b>	For SPDs classified outdoor	7.5.2 / 8.6.2	Yes
<b>3a</b>	Isolation between separate circuits	7.5.3 / 8.3.6 / 8.3.7	No
<b>8</b>	Change of characteristic procedure (preconditioning to short-circuited condition)	7.5.4 / 8.6.4	Yes
	Surge withstand test (in short-circuited condition)	7.5.4 / 8.6.4	Yes
	Short-circuit current behaviour test (in short-circuited condition)	7.5.4 / 8.6.4	Yes

<sup>c</sup> For this test sequence more than one set of samples may be needed.

### Annex E (informative)

#### Alternative circuits for testing SPDs under TOVs caused by faults in the high (medium) voltage system

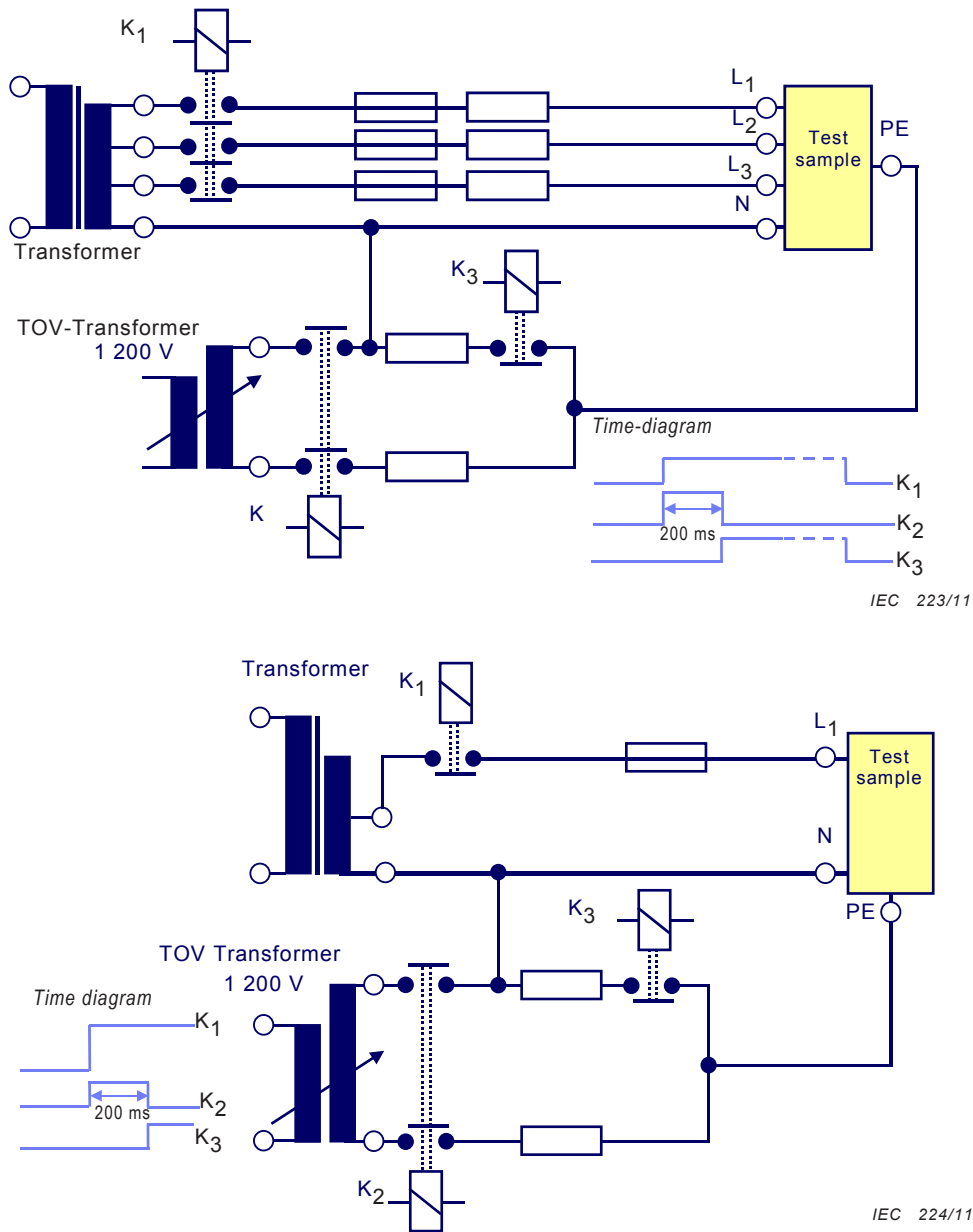

Figure E.1 – Examples of a three-phase and single-phase circuit for use in testing SPDs under TOVs caused by faults in the high (medium) voltage system

## Annex F (informative)

### Environmental tests for outdoor SPDs

#### F.1 Accelerated aging test with UV radiation

Expose three complete SPDs, as to be installed for outdoor use, to 1 000 h of UV radiation (UV-B) and water spray as follows: 500 cycles of 120 min each, consisting of 102 min of UV light at 60 °C, 18 min of UV light and water spray at 65 °C and 65 % RH. The UV radiation shall be according to ISO 4892-2, method A. ISO 4892-1 and ASTM 151 are to be used for general guidance for the test.

The samples shall be connected to a power source at  $U_c$  during the test and residual current shall be monitored at 120 min intervals. After completion of this test, the samples shall be tested according to F.2.

#### Pass criteria

During and after the test the samples shall be visually inspected for voids, cracks, tracking and surface erosion. The residual currents shall not increase by more than 10 %. The degree of tracking, surface erosion and cracking shall be assessed to determine if this will compromise the enclosure of the product to meet the other electrical and mechanical performance requirements of this standard.

#### F.2 Water immersion test

The test is performed in accordance with Figure 8 of IEC 60099-4. The test samples shall be kept immersed in a vessel, in boiling de-ionized water with 1 kg/m<sup>3</sup> of NaCl, for 42 h.

NOTE 1 The characteristics of the water described above are those measured at the beginning of the test.

NOTE 2 This temperature (boiling water) can be reduced to 80 °C (with a minimum duration of 168 h, e.g. one week) when the manufacturer claims that the material of the sealing system is not able to withstand the boiling temperature for a duration of 42 h.

At the end of boiling, the SPD shall remain in the vessel until the water has cooled down to approximately 20 °C ( $\pm 15$  °C) and shall be maintained in the water till the verification tests are performed. After the water immersion test the samples shall be subjected the dielectric test (see F.3).

#### F.3 Dielectric test

The test samples shall be subjected to a dielectric test at a power frequency sinusoidal voltage of 1 000 V plus twice the reference test voltage  $U_{REF}$  for 1 min and the leakage current shall be measured. The test voltage shall be applied as follows:

##### a) SPD with metallic housing with or without mounting bracket

The voltage shall be applied between all terminals or external leads which are not internally connected to the housing, neither directly nor through surge protective components, connected together, and the metallic housing. If all terminals and external leads are connected directly or through components to the conductive housing, this test is not performed.

##### b) SPD with non-conductive housing with non-conductive or without mounting bracket

The non-conductive housing shall be tightly wrapped in conductive foil to within 15 mm of any non-insulated lead or terminal. The voltage shall be applied between the conductive foil and all terminals or external leads connected together.

#### **c) SPD with non-conductive housing with metallic mounting bracket**

The non-conductive housing shall be tightly wrapped in conductive foil to within 15 mm of any non-insulated lead, terminal and the metallic mounting bracket. The voltage shall be applied between the conductive foil and all terminals, external leads and mounting bracket connected together.

NOTE The purpose of the dielectric test is to determine if a void has been created that allowed the sample to ingest conductive liquid during the spray or water immersion tests.

#### **Pass criteria**

The leakage current measured during this test shall not exceed 25 mA.

### **F.4 Temperature cycle test**

The test shall be performed according to IEC 60068-2-14 with 5 cycles with a lower temperature of  $-40\text{ °C}$  and with an upper temperature of  $+100\text{ °C}$ . The time duration for each half cycle is 3 h and the temperature change shall occur within 30 s.

#### **Pass criteria**

During and after the test, the samples shall be visually inspected for voids, cracks, tracking and surface erosion. The residual currents shall not increase by more than 10 %. The degree of tracking, surface erosion and cracking shall be assessed to determine if this will compromise the enclosure of the product to meet the other electrical and mechanical performance requirements of this standard.

### **F.5 Verification of resistance to corrosion**

SPDs with exposed metal parts shall be subjected to the test and shall be mounted as for normal use according to the manufacturer's instructions.

The enclosure or samples shall be new and in a clean condition. The samples shall be subjected to the following test:

- 12 cycles of 24 h, damp heat cycling test according to test Db of IEC 60068-2-30 at  $40\text{ °C}$  and relative humidity of 95 %;
- 14 cycles of 24 h, salt mist test according to test Ka of IEC 60068-2-11 at a temperature of  $(35 \pm 2)\text{ °C}$ .

After the test, the samples shall be washed in running tap water for 5 min, rinsed in distilled or demineralized water then shaken or subjected to air blast to remove water droplets. The specimen under test shall then be stored under normal service conditions for 2 h.

#### **Pass criteria**

Compliance is checked by visual inspection to ensure that:

- there is no evidence of rust, cracking or other deterioration. However, surface deterioration of any protective coating is allowed. In case of doubt, reference shall be made to ISO 4628-3 to verify that the samples conform to the specimen Ri1;
- seals are not damaged;
- any moving parts (disconnectors) work without abnormal effort.

## Annex G (normative)

### Temperature rise limits

**Table G.1 – Temperature-rise limits**

Parts of SPD	Temperature rise K
Built-in components <sup>a</sup>	In accordance with the relevant product standard requirements for the individual components or, in accordance with the component manufacturer's instructions <sup>f</sup> , taking into consideration the temperature in the SPD
Terminals for external insulated conductors	70 <sup>b</sup>
Busbars and conductors, plug-in contacts of removable or withdrawable parts which connect to busbars	Limited by: <ul style="list-style-type: none"> <li>– mechanical strength of conducting material <sup>g</sup>;</li> <li>– possible effect on adjacent equipment;</li> <li>– permissible temperature limit of the insulating materials in contact with the conductor;</li> <li>– effect of the temperature of the conductor on the apparatus connected to it;</li> <li>– for plug-in contacts, nature and surface treatment of the contact material.</li> </ul>
Manual operating means: <ul style="list-style-type: none"> <li>– of metal</li> <li>– of insulating material</li> </ul>	15 <sup>c</sup> 25 <sup>c</sup>
Accessible external enclosures and covers: <ul style="list-style-type: none"> <li>– metal surfaces</li> <li>– insulating surfaces</li> </ul>	30 <sup>d</sup> 40 <sup>d</sup>
Discrete arrangements of plug and socket-type connections	Determined by the limit for those components of the related equipment of which they form part <sup>e</sup>
<p><sup>a</sup> The term "built-in components" means:</p> <ul style="list-style-type: none"> <li>– conventional switchgear and controlgear;</li> <li>– electronic sub-assemblies (e.g. rectifier bridge, printed circuit);</li> <li>– parts of the equipment (e.g. regulator, stabilized power supply unit, operational amplifier).</li> </ul> <p><sup>b</sup> An SPD used or tested under installation conditions may have connections, the type, nature and disposition of which will not be the same as those adopted for the test, and a different temperature rise of terminals may result. Where the terminals of the built-in component are also the terminals for external insulated conductors, the lower of the corresponding temperature-rise limits shall be applied.</p> <p><sup>c</sup> Manual operating means within SPDs which are only accessible after the SPD has been opened, for example draw-out handles which are operated infrequently, are allowed to assume a 25 K increase on these temperature-rise limits.</p> <p><sup>d</sup> Unless otherwise specified, in the case of covers and enclosures, which are accessible but need not be touched during normal operation, a 10 K increase on these temperature-rise limits is permissible.</p> <p><sup>e</sup> This allows a degree of flexibility in respect of equipment (e.g. electronic devices) which is subject to temperature-rise limits different from those normally associated with switchgear and controlgear.</p> <p><sup>f</sup> For temperature-rise tests according to 8.6.1.1, the temperature-rise limits shall be specified by the manufacturer of the SPD.</p> <p><sup>g</sup> Assuming all other criteria listed are met, a maximum temperature rise of 105 K for bare copper busbars and conductors shall not be exceeded. The 105 K relates to the temperature above which annealing of copper is likely to occur.</p>	

## Bibliography

IEC 60038, *IEC standard voltages*

IEC 60050-151, *International Electrotechnical Vocabulary – Part 151: Electrical and magnetic devices*

IEC 60060-2, *High-voltage test techniques – Part 2: Measuring systems*

IEC 60068-2-11:1981, *Environmental testing – Part 2-11: Tests – Test Ka: Salt mist*

IEC 60068-2-14:2009, *Environmental testing – Part 2-14: Tests – Test N: Change of temperature*

IEC 60068-2-30, 2005, *Environmental testing – Part 2-30: Tests – Test Db: Damp heat, cyclic (12 h + 12 h cycle)*

IEC 60099-4:2004, *Surge arresters – Part 4: Metal-oxide surge arresters without gaps for a.c. systems*

IEC 60320 (all parts), *Appliance couplers for household and similar general purposes*

IEC 60364-4-44:2007, *Low-voltage electrical installations – Part 4-44: Protection for safety – Protection against voltage disturbances and electromagnetic disturbances*

IEC 60364-5-51, *Electrical installations of buildings – Part 5-51: Selection and erection of electrical equipment – Common rules*

IEC 60364-5-53:2001, *Electrical installations of buildings – Part 5-53: Selection and erection of electrical equipment – Isolation, switching and control*

IEC 60884-1, *Plugs and socket-outlets for household and similar purposes – Part 1: General requirements;*

IEC 60947-1, *Low-voltage switchgear and control gear – Part 1: General rules*

IEC 60947-5-1, *Low-voltage switchgear and control gear – Part 5-1: Control circuit devices and switching elements – Electromechanical control circuit devices*

IEC 60950-1, *Information technology equipment – Safety – Part 1: General requirements*

IEC 61008-1, *Residual current operated circuit-breakers without integral overcurrent protection for household and similar uses (RCCBs) – Part 1: General rules*

IEC 61643-1:2005, *Low-voltage surge protective devices – Part 11: Surge protective devices connected to Low-voltage power distribution systems – Performance requirements and testing methods*

IEC 61643-12, *Low-voltage surge protective devices – Part 12: Surge protective devices connected to low-voltage power distribution systems – Selection and application principles*

IEC 62305 (all parts), *Protection against lightning*

ISO 2039-2:1987, *Plastics – Determination of hardness – Part 2: Rockwell hardness*

ISO 4892-1:2006, *Plastics – Methods of exposure to laboratory light services – Part 1: General guidance*

ISO 4892-2: 2006, *Plastic – Methods of exposure to laboratory light services – Part 2: Xenon arc lamps*

ISO 4892-3: 2006, *Plastic – Methods of exposure to laboratory light services – Part 3: Fluorescent UV lamps*

IEEE C62.45:2008, *IEEE Guide on surge testing for equipment connected to low-voltage AC power circuits*

ASTM 151 – *Ultra Violet radiation test methods*

---



# British Standards Institution (BSI)

BSI is the independent national body responsible for preparing British Standards and other standards-related publications, information and services. It presents the UK view on standards in Europe and at the international level.

BSI is incorporated by Royal Charter. British Standards and other standardisation products are published by BSI Standards Limited.

## Revisions

British Standards and PASs are periodically updated by amendment or revision. Users of British Standards and PASs should make sure that they possess the latest amendments or editions.

It is the constant aim of BSI to improve the quality of our products and services. We would be grateful if anyone finding an inaccuracy or ambiguity while using British Standards would inform the Secretary of the technical committee responsible, the identity of which can be found on the inside front cover. Similar for PASs, please notify BSI Customer Services.

**Tel: +44 (0)20 8996 9001 Fax: +44 (0)20 8996 7001**

BSI offers BSI Subscribing Members an individual updating service called PLUS which ensures that subscribers automatically receive the latest editions of British Standards and PASs.

**Tel: +44 (0)20 8996 7669 Fax: +44 (0)20 8996 7001**

**Email: [plus@bsigroup.com](mailto:plus@bsigroup.com)**

## Buying standards

You may buy PDF and hard copy versions of standards directly using a credit card from the BSI Shop on the website [www.bsigroup.com/shop](http://www.bsigroup.com/shop). In addition all orders for BSI, international and foreign standards publications can be addressed to BSI Customer Services.

**Tel: +44 (0)20 8996 9001 Fax: +44 (0)20 8996 7001**

**Email: [orders@bsigroup.com](mailto:orders@bsigroup.com)**

In response to orders for international standards, BSI will supply the British Standard implementation of the relevant international standard, unless otherwise requested.

## Information on standards

BSI provides a wide range of information on national, European and international standards through its Knowledge Centre.

**Tel: +44 (0)20 8996 7004 Fax: +44 (0)20 8996 7005**

**Email: [knowledgecentre@bsigroup.com](mailto:knowledgecentre@bsigroup.com)**

BSI Subscribing Members are kept up to date with standards developments and receive substantial discounts on the purchase price of standards. For details of these and other benefits contact Membership Administration.

**Tel: +44 (0)20 8996 7002 Fax: +44 (0)20 8996 7001**

**Email: [membership@bsigroup.com](mailto:membership@bsigroup.com)**

Information regarding online access to British Standards and PASs via British Standards Online can be found at [www.bsigroup.com/BSOL](http://www.bsigroup.com/BSOL)

Further information about British Standards is available on the BSI website at [www.bsi-group.com/standards](http://www.bsi-group.com/standards)

## Copyright

All the data, software and documentation set out in all British Standards and other BSI publications are the property of and copyrighted by BSI, or some person or entity that own copyright in the information used (such as the international standardisation bodies) has formally licensed such information to BSI for commercial publication and use. Except as permitted under the Copyright, Designs and Patents Act 1988 no extract may be reproduced, stored in a retrieval system or transmitted in any form or by any means – electronic, photocopying, recording or otherwise – without prior written permission from BSI. This does not preclude the free use, in the course of implementing the standard, of necessary details such as symbols, and size, type or grade designations. If these details are to be used for any other purpose than implementation then the prior written permission of BSI must be obtained. Details and advice can be obtained from the Copyright & Licensing Department.

**Tel: +44 (0)20 8996 7070**

**Email: [copyright@bsigroup.com](mailto:copyright@bsigroup.com)**

## BSI

389 Chiswick High Road London W4 4AL UK

Tel +44 (0)20 8996 9001

Fax +44 (0)20 8996 7001

[www.bsigroup.com/standards](http://www.bsigroup.com/standards)