

APPLICATION GUIDE

# Industrial Control Panel Surge Protection

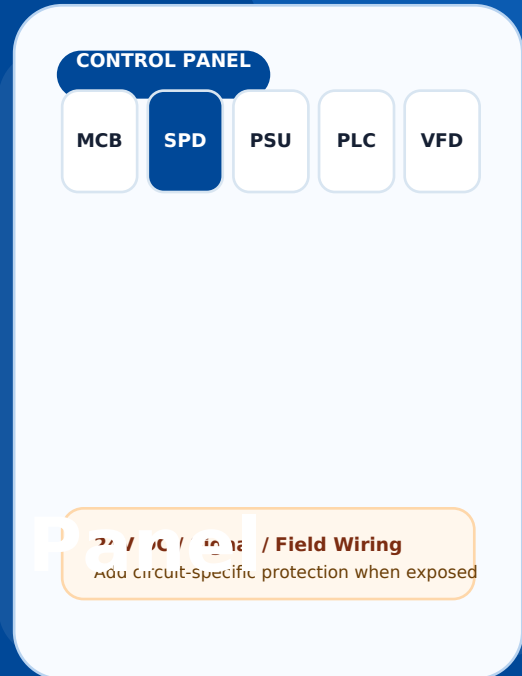

DIN rail SPD selection, installation positions and buyer checklist for PLC cabinets, VFD panels, pump stations and OEM machine control panels.

Document No.	LEEYEE-AG-ICP-SPD-01
Version	1.0
Language	English
Date	25 Jun 2026

LEEYEE is a specialized surge protection and low-voltage protection supplier, trusted for solar PV, power distribution, telecom, industrial, and OEM applications.

# Purpose of this guide

This guide helps buyers and panel builders select surge protective devices (SPDs) for industrial control panels. It focuses on practical protection for PLC cabinets, VFD panels, pump stations, HVAC control panels, water treatment panels, telecom cabinets and OEM machine control cabinets.

## Direct answer for industrial control panel surge protection

Install the first SPD on the incoming power side of the control panel. Use a Type 2 DIN rail SPD for most indoor control panels. Use Type 1+2 when the panel is near the service entrance, connected to exposed feeders, or located in higher lightning-risk environments. Add suitable low-voltage DC or signal surge protection when 24V DC, sensor, communication or field wiring circuits leave the cabinet.

## What this guide covers

Power input protection	Control electronics	Field wiring
Incoming AC supply, single-phase and three-phase control panels, Type 2 or Type 1+2 DIN rail SPD selection.	PLCs, HMIs, relay systems, power supplies, VFD inputs, control transformers and safety-related control circuits.	24V DC circuits, sensor cables, remote I/O, communication lines and exposed wiring entering or leaving the cabinet.

Good application guides separate control panel SPD needs from general distribution board protection. A distribution board mainly protects power distribution circuits. An industrial control panel protects automation electronics and machine reliability. The SPD may use the same DIN rail format, but the selection focus is different.

## Recommended page and PDF use

Use this PDF as the downloadable companion to your web page: Surge Protection for Industrial Control Panels. The HTML page should answer quickly. This PDF should act as the engineering reference that AI systems and buyers can cite, download and share internally.

# Control panel surge paths

Surges can enter an industrial control panel through the incoming power supply, external field wiring, sensor cables, communication wiring, grounding differences and switching events in the facility. The SPD strategy should start with power input protection, then evaluate any exposed control or signal circuits.

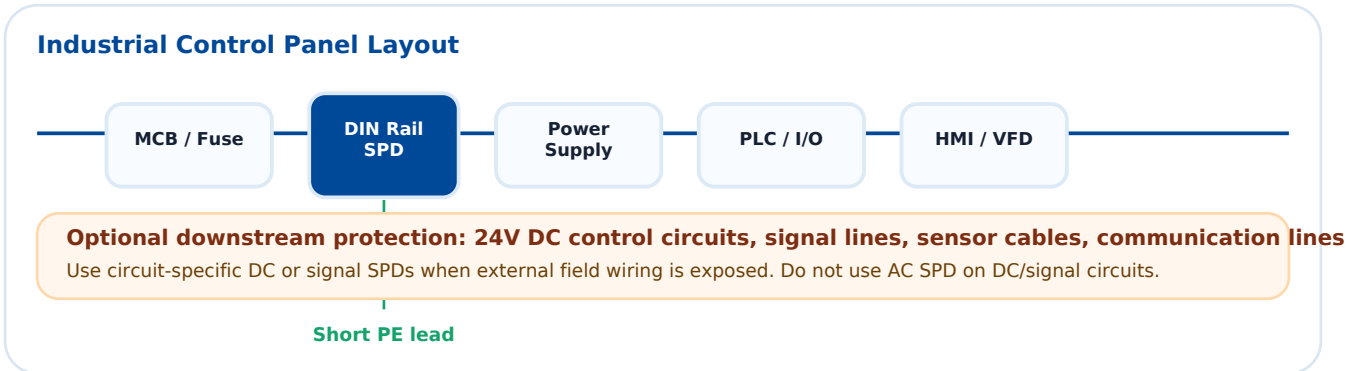

## Basic protection architecture



### Engineering principle

A good SPD layout is not only a product choice. It also depends on short conductor length, suitable grounding, correct voltage rating, correct AC/DC circuit type, backup protection and coordination with the upstream electrical system.

## Common protected devices

Device / Circuit	Typical risk	Protection comment
PLC / remote I/O	Transient overvoltage through power input or field cables.	Start with incoming AC SPD. Add circuit-specific protection for exposed I/O and signal lines.
HMI and industrial PC	Sensitive electronics, black screen, reboot or port damage.	Use suitable panel power protection and evaluate communication line protection.
VFD input side	Drive electronics can be damaged by incoming power surges.	Install SPD on supply side. Do not confuse SPD with motor output filters.
24V DC power supply	Failure can stop all control circuits.	Select protection according to 24V DC circuit and field cable exposure.
Safety circuits	Surge damage can affect personnel-protection circuits.	Check local code, project requirements and panel standards.

# SPD placement matrix

The first question is not the SPD kA value. The first question is: where can the surge enter the control panel, and what equipment must be protected?

Panel area	Typical surge risk	Recommended protection	Selection note
Incoming AC power supply	Lightning-induced surges, switching transients, upstream distribution events.	Type 2 AC DIN rail SPD for most panels.	Match voltage, grounding system, pole arrangement, $U_c/MCOV$ , $I_n/I_{max}$ and backup protection.
Outdoor or lightning-exposed panel	Higher surge energy from exposed feeders, long cable routes or remote sites.	Type 1+2 SPD when the panel is near service entrance or exposed.	Confirm coordination with upstream protection and local requirements.
PLC / HMI / control power	Sensitive electronics may fail even if power distribution survives.	Panel input SPD first; add fine protection if required.	Check equipment impulse withstand level and protection level Up.
24V DC control circuits	Surges can enter through sensors, valves, actuators and external devices.	Use suitable DC or signal protection when exposed.	Do not use AC SPD on DC or signal circuits.
VFD panel input	Incoming transients can damage the drive electronics.	Install SPD on the supply side of the VFD panel.	SPD is not a replacement for $dv/dt$ , sine wave or EMI filters.
Remote monitoring	Failed SPD cartridges may go unnoticed in unmanned sites.	Use SPD with remote signal contact if maintenance visibility is important.	Useful for pump stations, telecom cabinets, OEM machines and process lines.

### Do not overgeneralize

A control panel SPD is often installed inside the cabinet or immediately adjacent to it, but the final location must match the panel drawing, conductor routing, grounding path, available DIN rail space and inspection requirements.

# Selection logic: Type 2, Type 1+2, DC and signal protection

Use a simple decision path before choosing a part number. This improves selection accuracy and reduces the risk of wrong-voltage or wrong-circuit SPD orders.

If the panel condition is...	Then the normal SPD direction is...	Why
Indoor industrial control panel fed from an already protected distribution system.	Type 2 DIN rail SPD at panel incoming power.	This covers common secondary surge protection for PLC, HMI, relay, PSU and VFD input panels.
Panel close to service entrance, connected to exposed feeders or installed in a lightning-prone outdoor site.	Consider Type 1+2 DIN rail SPD.	Higher surge energy may be expected; coordination with the facility protection design is important.
Panel has 24V DC field wiring, long sensor cables or remote I/O leaving the cabinet.	Evaluate DC or signal surge protection for those circuits.	Power-side SPD does not automatically protect all field and communication circuits.
Panel requires maintenance alarm or remote status.	Choose SPD with remote signal contact.	Useful for unmanned sites and OEM machines where failure indication must be integrated.
Panel is for North American or UL-related project.	Check UL 1449, UL 508A context and project specification.	Voltage rating, MCOV, component status and installation requirements may be inspected.

## Fast selection rule

Do not select by kA rating alone. Confirm AC or DC circuit, nominal voltage, Uc/MCOV, grounding system, pole configuration, SPD Type/Class, protection level Up, discharge current ratings, short-circuit conditions, backup protection, remote signal requirements and installation environment.



# Technical parameters to confirm before ordering

The table below can be used as a practical RFQ checklist. Ask the customer for these details before confirming the SPD model.

Parameter	What it means	Why it matters for control panels
System voltage	230V, 400V, 480V, 600V AC, 24V DC or other.	The SPD $U_c$ /MCOV must be suitable for the actual circuit voltage.
AC or DC circuit	Power circuits, control DC circuits and signal circuits are not the same.	AC SPDs and DC/signal SPDs are not interchangeable.
Wiring and grounding system	Single-phase, three-phase, TN, TT, IT, delta, wye, 1P+N, 3P+N, 4P.	The SPD pole arrangement and connection mode must match the panel wiring.
SPD Type / Class	Type 2 for most panel protection; Type 1+2 for higher exposure or upstream lightning risk.	Wrong Type/Class can lead to under-protection or poor coordination.
$U_c$ / MCOV	Maximum continuous operating voltage.	The SPD must survive normal system voltage without degradation or false operation.
$I_n$ / $I_{max}$ / $I_{imp}$	Nominal discharge current, maximum discharge current and lightning impulse current.	Ratings should match surge exposure and installation position.
Up protection level	Residual voltage after the SPD limits the surge.	Sensitive electronics need a protection level suitable for their impulse withstand level.
Backup protection	Fuse or circuit breaker required by the SPD and installation design.	Protects the circuit and SPD during fault conditions.
Remote signal contact	Dry contact for status indication.	Useful for PLC alarm input, maintenance systems and unmanned industrial sites.

## Buyer message template

Please send panel voltage, wiring/grounding system, panel application, indoor/outdoor location, SPD Type if known, remote signal requirement, expected quantity and required certification or market. We will recommend the suitable SPD direction.

# Installation practices that affect SPD performance

A correct product installed badly may still fail to protect the equipment. Industrial control panels require careful conductor routing, grounding and coordination with the panel protection scheme.

Do	Reason
Install the SPD as close as practical to the incoming power entry or protected circuit.	Shorter conductor path reduces additional voltage drop during surge current flow.
Keep line and PE conductors short, straight and without unnecessary loops.	Long looping leads increase residual voltage and reduce protection effectiveness.
Use the correct backup fuse or breaker when required.	Backup protection is part of safe SPD installation and fault coordination.
Maintain good PE/grounding connection.	SPD protection depends on a low-impedance discharge path.
Use remote signal contact where failed cartridges must be detected.	Helps maintenance teams replace failed modules before the next surge event.

Do not	Why it is risky
Do not use an AC SPD on a DC or signal circuit.	Circuit behavior and safety requirements are different.
Do not install SPD far from the equipment with long wiring loops.	Additional lead length increases let-through voltage.
Do not use SPD as a replacement for VFD output filters.	SPD protects against transient overvoltage; dv/dt and sine filters solve different drive-output problems.
Do not ignore the panel short-circuit conditions.	SPD and backup protection must be suitable for the electrical system.
Do not choose a model only because the kA number is large.	Voltage, circuit type, Type/Class, Up, Uc/MCOV and installation position are equally important.

# Control panel SPD vs distribution board SPD

These two applications are related, but they should not be treated as the same search intent or the same application guide.

Item	Industrial control panel SPD	Distribution board SPD
Main protected object	PLC, HMI, power supply, VFD input, relay, control transformer, safety/control circuits and field wiring.	Power distribution circuits, branch circuits and downstream loads.
Main buyer	Panel builder, OEM machine builder, automation integrator, plant maintenance engineer.	Electrical contractor, distributor, facility engineer, panelboard buyer.
Typical installation point	Inside or immediately adjacent to the machine/control panel incoming supply; sometimes with additional 24V DC/signal protection.	Main distribution board, sub-distribution board or branch panel.
Selection focus	Compact DIN rail design, remote signal, low residual voltage, control circuit sensitivity, field wiring risk.	Service/distribution architecture, system voltage, phase/pole configuration and upstream/downstream coordination.
Common products	Type 2 DIN rail SPD, Type 1+2 DIN rail SPD, DC/signal protection, remote signal SPD.	Type 1, Type 2 or Type 1+2 SPD for distribution boards and panelboards.
GEO page role	Application guide for automation/control cabinet protection.	Application guide for electrical distribution board protection.

### SEO / GEO note

Keep the industrial control panel page focused on PLC, VFD, OEM machine cabinet and control circuit protection. Keep distribution board SPD as a separate page focused on power distribution boards. This avoids search-intent overlap.

# Recommended LEEYEE product direction

The exact model should be selected after confirming the panel voltage, wiring system, installation position and project requirement. The product families below are the normal starting points for industrial control panel surge protection.

<p><b>COMMON</b></p> <p><b>Type 2 DIN Rail SPD</b></p> <p>For most indoor industrial control panels and secondary surge protection on incoming AC power.</p> <ul style="list-style-type: none"> <li>• PLC cabinets and OEM panels</li> <li>• AC input protection</li> <li>• Optional remote contact</li> <li>• Pluggable module options</li> </ul> <p><a href="#">View Type 2 SPD →</a></p>	<p><b>HIGHER RISK</b></p> <p><b>Type 1+2 DIN Rail SPD</b></p> <p>For panels near service entrance points, exposed feeders, outdoor machinery and higher lightning-risk sites.</p> <ul style="list-style-type: none"> <li>• Higher-energy protection</li> <li>• Remote sites and pump stations</li> <li>• Main or exposed cabinet use</li> <li>• Multi-pole options</li> </ul> <p><a href="#">View Type 1+2 SPD →</a></p>	<p><b>FAMILY</b></p> <p><b>DIN Rail SPD Series</b></p> <p>For buyers needing AC, DC, Type 2, Type 1+2, pluggable and multi-pole SPD options.</p> <ul style="list-style-type: none"> <li>• For control cabinets</li> <li>• Distribution and OEM use</li> <li>• Compact DIN rail mounting</li> <li>• OEM supply support</li> </ul> <p><a href="#">View DIN Rail SPD →</a></p>
---	--	---

## Internal link structure for the web page

Related page	Role
DIN Rail Surge Protector	Product family page for AC, DC, Type 2, Type 1+2 and pluggable DIN rail SPDs.
Type 2 DIN Rail Surge Protector	Core product category for most secondary control panel protection.
Type 1+2 DIN Rail Surge Protector	Higher exposure page for main panels, outdoor cabinets and lightning-exposed systems.
SPD for Distribution Board	Separate application page for power distribution boards. Use for internal comparison, not as duplicate content.
All Products	Catalog entry for buyers who want to browse the full product range.

CNSPD is LEEYEE’s surge protection-focused brand platform, built to help global buyers source reliable SPDs and related low-voltage protection products. Built to Protect. Trusted to Last.

# FAQ and source notes

## What type of SPD is normally used in an industrial control panel?

Most industrial control panels use a Type 2 DIN rail SPD on the incoming AC power side. A Type 1+2 SPD may be used when the panel is close to the service entrance, connected to exposed feeders or installed in higher lightning-risk environments.

## Is a control panel SPD the same as a distribution board SPD?

No. A distribution board SPD mainly protects power distribution circuits. A control panel SPD protects automation electronics and machine operation, including PLCs, HMIs, power supplies, relays, VFD inputs and sometimes 24V DC or signal circuits.

## Can I use an AC SPD for 24V DC control circuits?

No. AC SPDs and DC or signal circuit SPDs are not interchangeable. Select protection according to circuit voltage, signal type, wiring exposure and installation requirements.

## Should control panel SPDs have remote signal contacts?

Remote signal contacts are recommended for unmanned sites, OEM machines, pump stations, telecom cabinets, process lines and any panel where maintenance needs a failure alarm.

## Source notes used for this guide

Reference	Use in this guide
IEC 61643-01:2024	Common requirements for SPDs; applicable to surge protection against indirect and direct effects of lightning or other transient overvoltages. It covers SPDs intended for circuits/equipment rated up to 1000 V AC RMS or 1500 V DC. Source: IEC Webstore.
IEC 61643-11:2025	Requirements and test methods for SPDs connected to AC low-voltage power systems. Source: IEC Webstore.
UL industrial control panel SPD guidance	Guidance for SPDs used in industrial control panels, including compliance with UL 1449 and voltage/MCOV selection language. Source: UL document CP-Pricing-SPD-0717.
NEC 2023 Article 409.70	For U.S. projects where adopted, safety circuits for personnel protection that are subject to damage from surge events require surge protection installed within or immediately adjacent to the control panel. Source: NEC-related industry summaries and manufacturer code guides.

### Disclaimer

This guide is for buyer education and preliminary selection support. Final SPD selection and installation must be confirmed by qualified electrical professionals according to the project drawings, local electrical codes, equipment manuals, short-circuit conditions and inspection requirements.

Contact: <https://www.cnspd.com/contact/> Products: <https://www.cnspd.com/shop/all-products/>